

NDV SANITARY VALVES



SANITARY VALVES

Contents

| | | |
|--|----|-----------|
| Product Guide | 4 | |
| Product List | 6 | |
| 1. Bioclean Diaphragm Valves | | 7 |
| 1-1. Features of Bioclean Diaphragm Valves | 8 | |
| 1-2. Standard Specifications | 10 | |
| 1-3. Manually Operated Valves | 12 | |
| 1-4. Pneumatically Operated ON-OFF Valves (Standard): BPO1400NB(N) | 13 | |
| 1-5. Pneumatically Operated ON-OFF Valves (Stainless Steel Actuator): BPO1400N .. | 15 | |
| 2. Products for Dead Spaces Bioclean Diaphragm Valve Series | | 17 |
| 2-1. Self-Drain Valves: Type-F | 18 | |
| 2-2. Sampling Valves: Type-P | 19 | |
| 2-3. 3-Way Valves: Type-K | 20 | |
| 2-4. Tank Bottom Valves: Type-T | 21 | |
| 3. Special Valves · Related Products Bioclean Diaphragm Valve Series | | 23 |
| 3-1. Branch Valves | 24 | |
| 3-2. Combination Valves, Multi-Branch Valves | 26 | |
| 3-3. Other Related Products | 27 | |
| 4. Sanitary Valves · Clean Room Related Products | | 29 |
| 4-1. Sanitary Ball Valves | 30 | |
| 4-2. Sanitary Check Valves | 33 | |
| 4-3. Sanitary Butterfly Valves | 34 | |
| 4-4. Powder & Granule / Tablet Discharge Valves | 35 | |
| 4-5. Ultra-High Airtight Dampers | 36 | |
| 5. Technical Materials | | 39 |
| ① Valve Main Body Dimension List | 40 | |
| ② Inspection Pressure | 42 | |
| ③ Cleaning Specifications | 42 | |
| ④ Valve Stroke and Cv-Value | 42 | |
| ⑤ Pneumatically Operated ON-OFF Actuator Selection Table: Operating Pressure 0.3 MPa | 42 | |
| ⑥ Product Code Descriptions | 43 | |
| ⑦ Air Chamber Volumes and Air Consumption for BPO1400NB(N) | 44 | |
| ⑧ Test Certificates | 44 | |
| 6. Safety Instructions | | 45 |

PRODUCT GUIDE

Bioclean Diaphragm Valves

Manually Operated Valves



Stainless Steel Handle
B400N
DN8-100



Aluminum Handle
BC400
DN15-50



Quick Open/Close Handle
BQL400NB(N)
DN8-80

Pneumatically Operated ON-OFF Valves



BPO (PC, PN) 1400NB
DN15-50



Opening Limit Device



with Special Limit Switch Box



BPO (PC, PN) 1400N
DN65-100

Pneumatically Operated ON-OFF Valves (Stainless Steel Actuator)



BPO (PC, PN) 1400N
DN8-10



BPO (PC, PN) 1400N
DN15-50

Products for Dead Spaces

Self-Drain Valve
Type-F



DN8-100

Sampling Valve
Type-P



DN8-100

3-Way Valve
Type-K



DN8-80

Tank Bottom Valve
Type-T



DN15-100

Please feel free to contact our sales dept. or local representative for detailed product specifications

Special Valves · Related Products

Branch Valve



B400 (A-L)

Combination Valve,
Multi Branch Valve



Ferrule Connection
Corrosion-Proof Valve



B460 (S)



B414 (C1)

Two Stage
Open/Close Actuator



Steam Trap
Substituting Valve



B400 (R)

Sanitary Valves · Clean Room Related Products

Sanitary Valve



Powder & Granule / Tablet
Discharge Valve



Ultra-High Airtight Damper



The pictures in this catalogue show the images. The appearances may vary depending on the specification.

Product List

Bioclean Diaphragm Valve Series

○: Standard ☆: Option —: Not Applied

| | | Standard 2-Way Valves | | | | Valves for Dead Spaces | | | | Special Valves*** | | | |
|---|-------------|-----------------------|------|---------------|-----------------------|------------------------|----------|----------|----------|-------------------|-------------|-------------------|--------------|
| | | Stainless Steel Body | | Lined Body | | Self-Drain | | | | Sampling Valve | 3-Way Valve | Tank Bottom Valve | Branch Valve |
| | | B414 | B413 | B459 (2S)/(S) | B459 (M) | B460 (S) | B414 (F) | B413 (F) | B459 (F) | B414 (P) | B414 (K) | B414 (T) | B414 (A-L) |
| Connection Standard | ISSC | ○ | ○ | —** | — | ○ | — | — | — | ○ | — | — | |
| | JT | ☆ | ☆ | — | — | — | — | — | — | ☆ | — | — | |
| Main Body Surface Finish Classification | J10KFF (RF) | ☆ | ☆ | ○ | ○ | — | — | — | — | ☆ | — | — | |
| | ISSU | ☆ | — | — | — | — | — | — | — | ☆ | — | — | |
| Main Body Material | B1 | ☆ | ○ | — | — | — | — | — | — | ☆ | ○ | — | |
| | B2 | ○ | — | — | — | — | — | — | — | ○ | — | — | |
| | B3 | ☆ | — | ☆ | Painted Outer Surface | ☆ | — | — | — | ☆ | — | — | |
| | B4 | — | — | ☆ | Surface (white) | ☆ | — | — | — | — | — | — | |
| | E1 | ☆ | — | — | — | — | — | — | — | ☆ | — | — | |
| | E2 | ☆ | — | — | — | — | — | — | — | ☆ | — | — | |
| Diaphragm | TX/CE | | | | | | | | | | | | |
| | TX/CX | | | | | | | | | | | | |
| Operation Type | Manual | | | | | | | | | | | | |
| | Auto | | | | | | | | | | | | |
| | | | | | | | | | | | | | |

* Please contact us for a possibility of producing a product other than the standard. ** With a manufacturing record of special clamp type. Please contact us for details. *** Other than this, specific orders for special valves and related products are welcome.
Please contact our sales dept. or local representative for materials and nominal sizes other than those listed in this table.

Bioclean Diaphragm Valves

1-1. Features of Bioclean Diaphragm Valves

1-2. Standard Specifications

- ① Valve Main Body Specifications
- ② Diaphragm Specifications
- ③ Working Temperature Range and Max. Working Pressure

1-3. Manually Operated Valves

- ① Handle Specifications: B400N, BC400 (B400NB), BQL400NB(N)
- ② Major Dimensions

1-4. Pneumatically Operated ON-OFF Valves (Standard): BPO1400NB(N)

- ① Features of Actuator
- ② Actuator Selection Table
- ③ Major Dimensions

1-5. Pneumatically Operated ON-OFF Valves (Stainless Steel Actuator): BPO1400N

- ① Features of Actuator
- ② Actuator Selection Table
- ③ Major Dimensions

1-1. Features of Bioclean Diaphragm Valves

Optimum valves for manufacturing equipment for medicine, bioprocesses, cosmetics, foods and semiconductors

1 Excellent Air-tightness

- A highly airtight structure perfectly separating the fluid and actuator by a diaphragm. The structure (Packless) that does not require a gland packing with high possibility of leakage as a general valve, is excellent for maintaining air tightness and prevention of contamination by various bacteria.

2 A Structure not Contaminating the Fluid

- The flow path consists only of main body and diaphragm and is an optimum structure preventing the contaminant materials or lubricants from contacting the fluid.
- The valve seat sealing method to press the diaphragm to the weir of main body does not require the rotational parts or sliding parts required for ball valves and butterfly valves, accordingly almost no abrasion particle is expected.

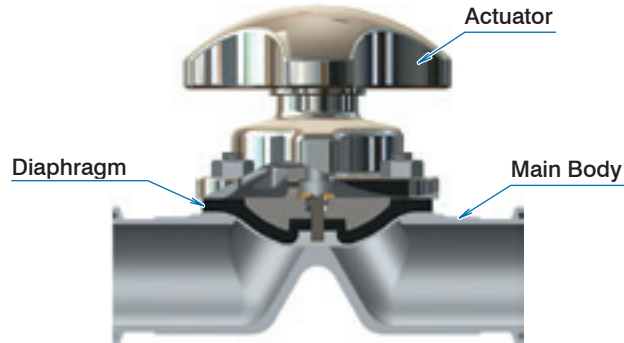

3 Excellent Washability

- The streamlined flow path eliminating the dead space (pockets or fluid accumulation) is excellent in washability and is a superior structure for CIP (cleaning in place) or SIP (sterilization in place) for its effectiveness and washing time.
- When attaching a valve on a horizontal pipework, installation with "TOP" mark in upper side will prevent the fluid, rinse solution, etc., from remaining inside.

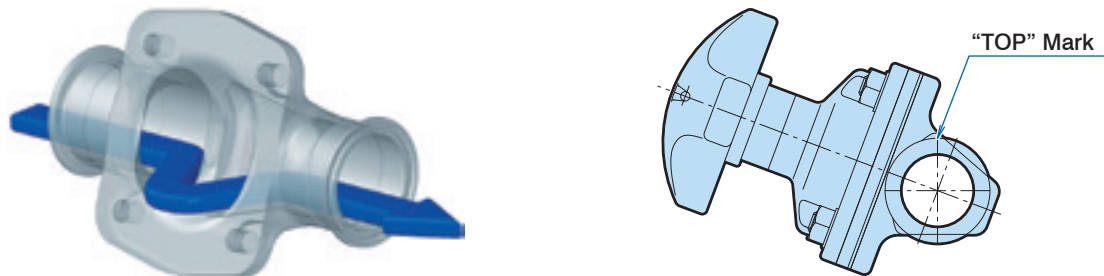

4 Excellent Maintainability

- A simple structure of diaphragm valve consisting of only three units "Actuator", "Diaphragm" and "Main Body"
- Disassembling is just to remove the bolts and nuts fastening the "Actuator", "Diaphragm" and "Main Body" and that provides the excellent maintainability. In addition, the top-entry structure allows the maintenance work without removing the valve body from piping.
- As one of the features of diaphragm valves, the original performance will be restored by replacing the diaphragm by new parts.
- The standard exchangeability of various units will provide the ease of changing actuators.

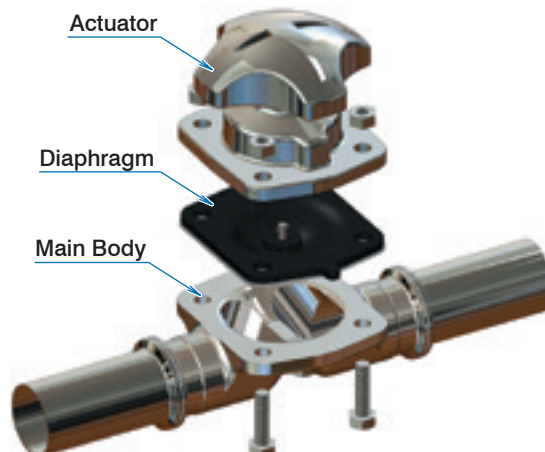

5 Manufacturing of Valve Main Unit Tailored to Applications and Specifications

- The streamlined flow path for main body made of stainless steel is buff finished (#400) and that allows further electropolishing facilitating the prevention of fluid accumulation, prevention of adhesion of substances in the fluid, and the improved washability. The outside surface of main body and actuator are ground as designated.
- A pocket free compact special shape for sampling valves, 3-way valves, and tank bottom valves are available while preserving the features of bioclean diaphragm valves as they are.
- The tailored manufacturing for fitting various joints such as ferrule joint (clamp joint) or welded types used in the fields of medical drugs, bio processes, semiconductors, etc., are available.



Sampling Valve: Type-P



3-Way Valve: Type-K



Tank Bottom Valve: Type-T

6 Excellent for Corrosion and Chemical Resistance

- The valve main bodies with optimum lining for countermeasures for corrosive fluids, crevice corrosion, and metal ion elution for sanitary pipework are available.
- PFA lining material complies with FDA standards and is listed on the Positive List under the Food Sanitation Act (Japan).
(Ref. ⑧ Test Certificates in 5. Technical Materials)



SUS316L + ETFE Lined Main Body
(Ferrule Connection)

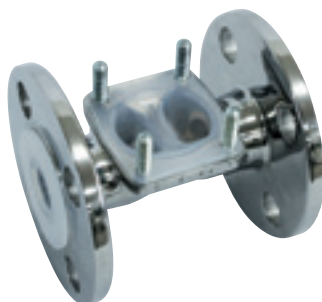

SCS13 + PFA Lined Main Body
(Flange Connection)

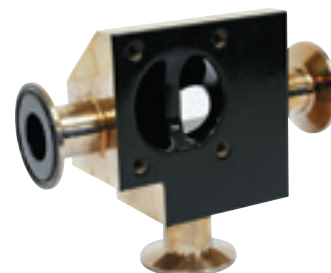

SUS316L + PFA Coated Main Body
3-Way Valves: Type-K
(Ferrule Connection)

7 Sanitary Specification Diaphragms

- Our New PTFE diaphragms are fluorocarbon resin diaphragms with excellent cleanliness, creep-resistance, penetration-resistance, and abrasion-resistance developed with our own techniques.
- Based on our extensive experience and reliable technological capabilities for more than half a century, we conduct various tests under severe conditions to confirm durability and safety.
- Compliant with FDA* and USP Class VI** standards. Materials used are listed on the Positive List under the Food Sanitation Act (Japan).

* Food and Drug Administration, HHS 21 CFR Ch.1 (4-1-94 Edition), §177.1550, §177.2600
(HHS: Department of Health and Human Services)
(CFR: Code of Federal Regulations)

** The conformance is recommended in ASME BPE (Bio Processing Equipment), "POLYMER" construction materials used for contacting surfaces with product material (contacting surface with product and fluid).

(Ref. ⑧ Test Certificates in 5. Technical Materials)



8 Environment Friendly

- Environment friendly paints are used for coating of actuator for bioclean diaphragm valves.
- Diaphragm valves have less number of parts compared to other valve types owing to a simple unit structure; accordingly, there is no waste of wearing parts.

9 Integrated Manufacturing System in Clean Room

Bioclean Diaphragm Valves are manufactured in the clean room with processes "1. Cleaning of fluid contacting parts", "2. Assembly", "3. Inspection" and "4. Packing" and finished to a clean product and delivered to the customers.

1-2. Standard Specifications

1 Valve Main Body Specifications

Stainless Steel Body

| Manufactured Main Bodies | | | Connection Standard and Manufacturing Range | | | |
|-------------------------------|---------------|---------------|---|----------------------|-------------------|-------------------|
| Name | Main Material | Material Code | Ferrule | Astro (TIG) Welding* | Union Screw* | Flange* |
| | | | Nominal Size (DN) | Nominal Size (DN) | Nominal Size (DN) | Nominal Size (DN) |
| Stainless Steel Forged | SUS316L | 14 | 8-100 | 8-100 | 25-100 | 8-100 |
| Stainless Steel Cast | SCS16 | 13 | 8-50 | 8-50 | — | 15-100 |

* Option

Main Body Surface Finish Classification

Please designate from table below:

| Classification Code | Process |
|---------------------|--|
| B1 | #400 Buffing: Inner/Outer Surfaces |
| B2 | #400 Buffing: Inner Surface* |
| B3 | #400 Buffing: Outer Surface* |
| E1 | Electropolishing after #400 Buffing on Inner/Outer Surfaces* |
| E2 | Electropolishing after #400 Buffing on Inner Surface* |

* For main bodies of forged stainless steel only



Standard Main Body (Ferrule)

Lined Main Bodies

| Manufactured Main Bodies | | | Connection Standard and Manufacturing Range | |
|--------------------------|---------------|----------------|---|-------------------|
| Name | Base Material | Material Code | Ferrule | Flange |
| | | | Nominal Size (DN) | Nominal Size (DN) |
| PFA Lining ☆ | SCS13 | 59 (2S)/59 (S) | — | 15-80 |
| | FCD-S | 59 (M)* | — | 15-100 |
| ETFE Lining ☆ | SUS316L | 60 (S) | 25-65 | — |

* Standard external painting (white)

• PFA lining material complies with FDA standards and is listed on the Positive List under the Food Sanitation Act (Japan).

(Ref. ⑧ Test Certificates in 5. Technical Materials)

☆: In case of export, export license stipulated in the Foreign Exchange and Foreign Trade Control Law of Japan and/or if necessary, export-related laws and regulations of the United States of America and other countries is required.



PFA Lining (Flange)

Main Body Surface Finish Classification (Option)

Please designate from table below:

| Classification Code | Process |
|---------------------|--|
| B3 | #400 Buffing: Outer Surface (No Burnt Color) |
| B4 | #400 Buffing: Outer Surface (Burnt Color) |

(For base material FCD-S: White painting for standard external painting, no grinding)

P.27



ETFE Lining (Ferrule)

Detailed Dimensions of Main Body

In accordance with P. 40 "Valve Main Body Dimension List"

Others

PFA Lining: Please contact us for special clamp connection types.

2 Diaphragm Specifications

The "New PTFE" diaphragm is adopted for fluid contacting side, and the cushion rubber (EPDM or EPDM + α) is applied for the backside for improved sealing performance of valve.

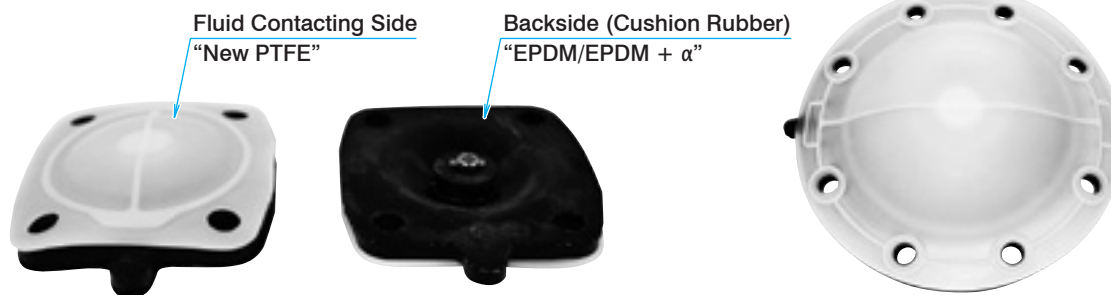

| Diaphragm/Cushion Rubber Material | Material Code | Nominal Size (DN) | Working Temperature Range | Max Working Pressure |
|-----------------------------------|---------------|-------------------|---------------------------|----------------------|
| New PTFE/EPDM | TX/CE | 8-100 | -20 to 143 °C | 1.0 MPa |
| New PTFE/EPDM + α | TX/CX | 8-100 | -20 to 151 °C | 1.0 MPa |

- EPDM + α is developed by our company for enhanced thermal durability of EPDM.
- The "New PTFE" diaphragm complies with FDA and USP class VI standards and is listed on the Positive List under the Food Sanitation Act (Japan). (Ref. ⑧ Test Certificates in 5. Technical Materials)
- Option: Fluorine Cushion Rubber, ALLOY C276 Diaphragm Fixing Bayonet Pin

3 Working Temperature Range and Max. Working Pressure

New PTFE/EPDM (TX/CE), Stainless Steel · PFA Lined Main Body*

Working Temperature Range: -20 to 143 °C

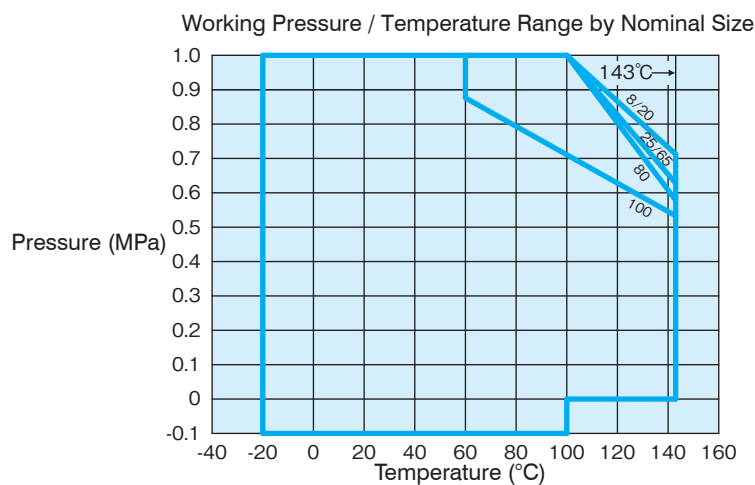

New PTFE/EPDM + α (TX/CX), Stainless Steel · PFA Lined Main Body*

Working Temperature Range: -20 to 151 °C (max. working temperature for continuous use)

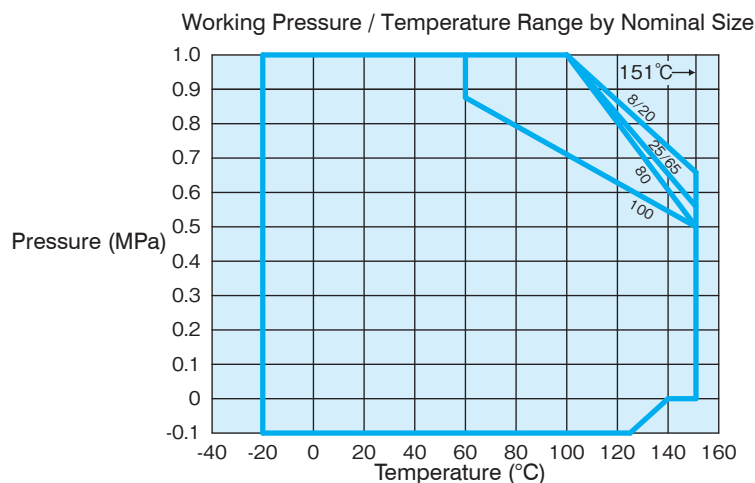

* Lower limit temperature for PFA lined main body made of base material FCD-S is -10 °C

1-3. Manually Operated Valves

1 Handle Specifications: B400N, BC400 (B400NB), BQL400NB(N)

Stainless Steel Handle Type: B400N

- Manual valves with highly durable stainless steel handle and ease of cleaning.

Standard Specifications

| | |
|----------------------------|----------------------------------|
| Nominal Size (DN) | 8-100 |
| Bonnet Material | SCS13A* Outside #250-400 Buffing |
| Handwheel Material | SCS13A* Outside #250-400 Buffing |
| Compressor Material | SCS13 |

* SCS13 for DN8-10

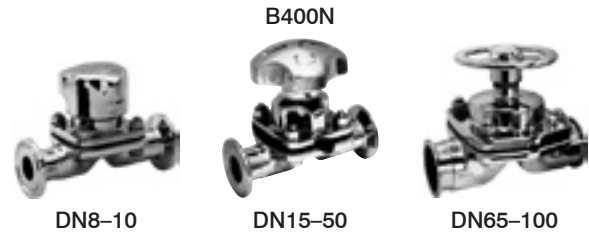

Aluminum Handle Type: BC400 (B400NB)

- Aluminum handle type lightweight and cost benefit conscious manual valves.

Standard Specifications

| | |
|--------------------------------|---|
| Nominal Size (DN) | 15-50* |
| Bonnet Material | ADC12 |
| Handwheel Material | ADC12 |
| Compressor Material | ADC12 |
| Standard Painting Color | White thermal curing acrylic resin paint (eco-friendly) baking finish |

* Separately supplied general-purpose aluminum handle B400NB (white painting) are available. Contact us for a detailed study.

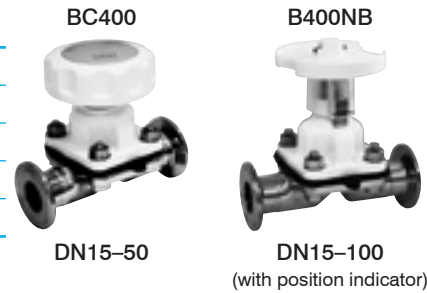

Quick Open/Close Handle: BQL400NB(N) (Option)

- Quarter turn (90°) actuator with lever handle. Stable closing performance with simple operation. (Max. Shutoff Differential Pressure 0.6 MPa)
- The valve status can be recognized with the handle position from far place like ball valves.
- Too tight closing by open/close operation can be prevented and the long life is expected with no excessive loading on diaphragm.

Standard Specifications

| | |
|------------------------------|---------------------------------------|
| Nominal Size (DN) | 8-80 |
| Bonnet Material | SCS13A Outside #400 Buffing |
| Lever Handle Material | SCS13A |
| Position Setting | Two positions: Full Close / Full Open |
| Option | Limit Switch |

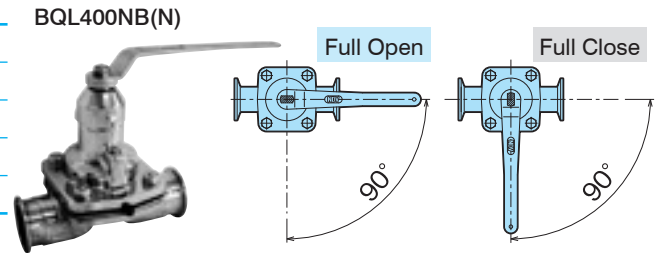

Other Options

- Valves with lock nut, position indicator, etc., are provided as requested. Please contact our sales dept. or local representative.

2 Main Dimensions

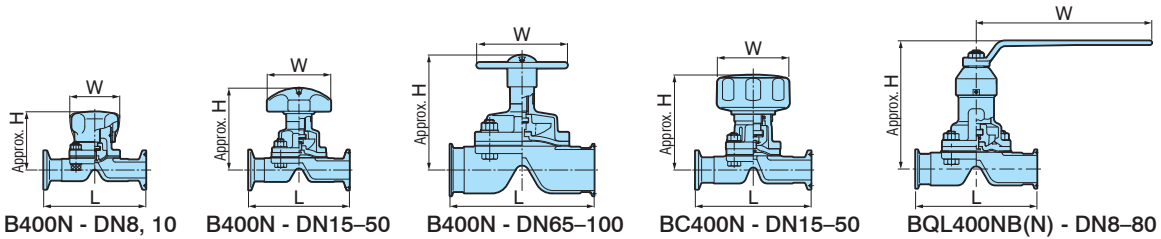

Unit: mm

| Nominal Size | DN | 8 | 10 | 15 | 20 | 25 | 40 | 50 | 65 | 80 | 100 |
|-------------------|---------------------|------|------|------|------|-----|-----|-----|-----|------|------|
| | S | — | — | — | — | 1 | 1.5 | 2 | 2.5 | 3 | 4 |
| L | Ferrule | 90 | 90 | 102 | 118 | 127 | 159 | 191 | 216 | 254 | 305 |
| | Astro (TIG) Welding | 80 | 80 | | | | | | | | |
| | Flange | 118 | 118 | | | | | | | | |
| | Union Screw | — | — | | | | | | | | |
| Approx. H | B400N | 56 | 56 | 93 | 98 | 103 | 132 | 148 | 185 | 203 | 258 |
| | BC400 | — | — | 84 | 92 | 108 | 137 | 164 | — | — | — |
| | BQL400NB(N) | 66 | 66 | 121 | 130 | 136 | 168 | 179 | 246 | 279 | — |
| W | B400N | 44 | 44 | 70 | 70 | 80 | 100 | 125 | 125 | 160 | 224 |
| | BC400 | — | — | 63 | 63 | | | | | | |
| | BQL400NB(N) | 90 | 90 | 130 | 130 | | | | | | |
| Mass (Approx. kg) | B400N | 0.43 | 0.4 | 1.1 | 1.3 | 1.3 | 2.3 | 3.8 | 7.0 | 12.0 | 16.0 |
| | BC400 | — | — | 0.71 | 0.88 | 1.1 | 1.9 | 2.9 | — | — | — |
| | BQL400NB(N) | 0.5 | 0.47 | 0.6 | 0.9 | 1.2 | 3.3 | 4.5 | 9.4 | 15.0 | — |

* The above table is based on Ferrule main body made of SUS316L. Contact us for detailed dimensions for each valve.

Bioclean Diaphragm Valves Manually Operated Valves
 Products for Dead Spaces
 Special Valves · Related Products
 Sanitary Valves · Clean Room Related Products
 Technical Materials
 Safety Instructions

1-4. Pneumatically Operated ON-OFF Valves (Standard): BPO1400NB(N)

1 Features of Actuator (BPO1400NB)

Bioclean Diaphragm Valves
Pneumatically Operated ON-OFF Valves

Products for Dead Spaces

Special Valves · Related Products

Sanitary Valves · Clean Room Related Products

Technical Materials

Safety Instructions

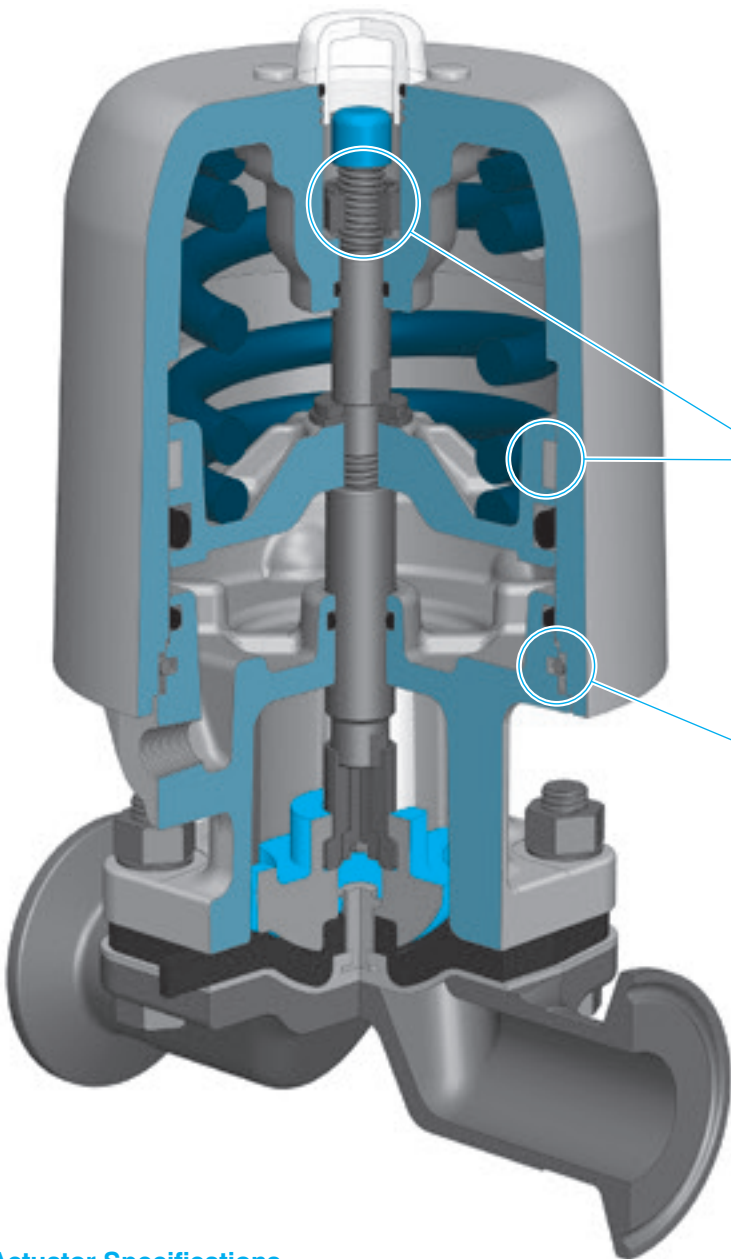

Significantly Light Weight, Compactness

- Comparison with our conventional product (BPO1400N)
- Mass: Max. weight reduction of approx. 13%!
 - Height: Max. compactification of 22%!
 - Outer Diameter: Max. compactification of 18%!
 - Air Consumption: Max. air saving of 20%!

Significantly Improved Smoothness of Action and Durability

- The adopted outer wear ring for the piston provides the smoothness of action to significantly enhance the durability.
- The adopted stopper nut prevents the excessive loading on diaphragm

Excellent External Shape for Cleaning

- The adopted retaining ring for fixing the bonnet and cylinder and the built-in exhausting plug improve the cleanability owing to the extreme reduction of surface roughness of actuator.

Eco-Friendly Paint

- Eco-friendly paint is adopted for the white baking finish on the actuator surface. (The corrosion proof performance of this paint was confirmed through the dip tests performed using various CIP liquid and washing agents.)

Actuator Specifications

| | |
|---|---|
| Types | BPO (BPC, BPN) 1400NB (N)* |
| Actuator Code | 07, 09, 12, 16, 16BN, 20BN, 25BN* |
| Types of Operation | Single Acting: Reverse Acting BPO (Air to Open / Spring to Close) Direct Acting BPC (Air to Close / Spring to Open) Double Acting: BPN (Air to Open / Air to Close) |
| Nominal Size (DN) | 15–100* |
| Actuator Materials | Cylinder: ADC12 Bonnet: ADC12 (SCS13A for BPO1400N) Standard Painting: White thermal curing acrylic resin paint (eco-friendly) baking finish |
| Operating Pressure | 0.4 ^{+0.1} ₀ MPa • Option: 0.3 ^{+0.1} ₀ MPa** |
| Max. Shutoff Differential Pressure | 1.0 MPa |
| Lubricants | Cassida Grease HDS2 (Standards regarding food additives: FDA 21 CFR 178.3570. Lubricants with permission of incidental contact with food: NSF Class H1 conforming product) |
| Options*** | Opening limit device, Special limit switch box (Eco-friendly type, white baking finish) |

* DN65–100 are equipped with BPO1400N - 16BN–25BN. The basic specifications, such as action performance with wear ring, corresponding options are the same.

** The 0.3 MPa actuator is equipped with BPO1400N. Please refer to page 42 for the actuator selection table.

*** The commercially-supplied accessories may be attached as requested. Please contact our sales dept. or local representative for the details.

2 Actuator Selection Table

Reverse Acting: BPO1400NB(N)

| | | New PTFE Diaphragm | | | | | | | | | |
|-------------------|---------------|------------------------|-----|------|------|-----|-----|-----|-----|------|-----|
| Nominal Size (DN) | Actuator | Working Pressure (MPa) | | | | | | | | | |
| | | 0.1 | 0.2 | 0.3 | 0.4 | 0.5 | 0.6 | 0.7 | 0.8 | 0.9 | 1.0 |
| 15 | 07 | | | | | | | | | | (*) |
| 20 | 09 | | | | | | | | | | |
| 25 | 09 | | | | | | | | | | (*) |
| 40 | 12 | | | | | | | | | | |
| 50 | 16 | | | | | | | | | | |
| 65 | Right Table** | | | 16BN | | | | | | 20BN | |
| 80 | Right Table** | | | 20BN | | | | | | 25BN | |
| 100 | Right Table** | | | | 25BN | | | | | | |

*Option, **BPO1400N

Direct Acting: BPC1400NB(N)

| | | New PTFE Diaphragm | | | | | | | | | |
|-------------------|---------------|------------------------|-----|-----|------|-----|-----|-----|------|-----|------|
| Nominal Size (DN) | Actuator | Working Pressure (MPa) | | | | | | | | | |
| | | 0.1 | 0.2 | 0.3 | 0.4 | 0.5 | 0.6 | 0.7 | 0.8 | 0.9 | 1.0 |
| 15 | 07 | | | | | | | | | | |
| 20 | 09 | | | | | | | | | | |
| 25 | 09 | | | | | | | | | | |
| 40 | 12 | | | | | | | | | | |
| 50 | 16 | | | | | | | | | | |
| 65 | Right Table** | | | | 16BN | | | | | | 20BN |
| 80 | Right Table** | | | | 20BN | | | | | | 25BN |
| 100 | Right Table** | | | | | | | | 25BN | | |

**BPC1400N

Double Acting: BPN1400NB(N)

| | | New PTFE Diaphragm | | | | | | | | | |
|-------------------|---------------|------------------------|-----|------|-----|------|-----|-----|-----|------|------|
| Nominal Size (DN) | Actuator | Working Pressure (MPa) | | | | | | | | | |
| | | 0.1 | 0.2 | 0.3 | 0.4 | 0.5 | 0.6 | 0.7 | 0.8 | 0.9 | 1.0 |
| 15 | 07 | | | | | | | | | | |
| 20 | 09 | | | | | | | | | | |
| 25 | 09 | | | | | | | | | | |
| 40 | 12 | | | | | | | | | | |
| 50 | 16 | | | | | | | | | | |
| 65 | Right Table** | | | | | 16BN | | | | | |
| 80 | Right Table** | | | | | | | | | 20BN | |
| 100 | Right Table** | | | 20BN | | | | | | | 25BN |

**BPN1400N

3 Major Dimensions

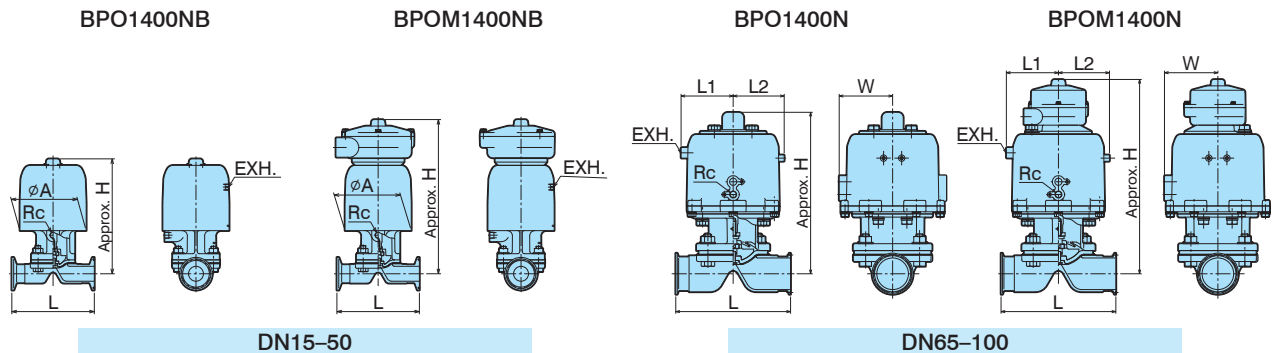

Unit: mm

| Nominal Size | Actuator | L | Approx. H | | Rc | φA | L1 | L2 | W | Mass (Approx. kg) | | |
|--------------|----------|-----|-------------|----------------|-----|-----|-----|-----|------|-------------------|---|------|
| | | | BPO BPC BPN | BPOM BPCM BPNM | | | | | | BPO | Added Mass of Special Limit Switches BPOM | |
| 15 | 07 | 102 | 145 | 206 | 1/8 | 87 | — | — | — | 1.3 | +1.0 | |
| 20 | 09 | 118 | 164 | 224 | | 102 | — | — | — | 2.0 | | |
| 25 | 09 | 127 | 177 | 237 | | 102 | — | — | — | 2.1 | | |
| 40 | 1.5 | 159 | 196 | 256 | | 138 | — | — | — | 4.3 | | |
| 50 | 2 | 191 | 237 | 298 | | 183 | — | — | — | 8.4 | | |
| 65 | 2.5 | 216 | 304 | 363 | 1/4 | — | 98 | 96 | 101 | 12.5 | +1.5 | |
| | 16BN* | | 355 | 414 | | — | 119 | 117 | 122 | 18.5 | | |
| 80 | 3 | 254 | 374 | 434 | | — | 119 | 117 | 122 | 22.7 | | +1.0 |
| | 20BN* | | 413 | 472 | | — | 143 | 143 | 147 | 36.1 | | |
| 100 | 4 | 305 | 393 | 452 | | — | 119 | 117 | 122 | 29.9 | | +1.0 |
| | 25BN* | | 431 | 490 | — | 143 | 143 | 147 | 43.3 | +1.5 | | |

* BPO1400N

• The above table is based on Ferrule main body made of SUS316L. Contact us for detailed dimensions for each valve.

1-5. Pneumatically Operated ON-OFF Valves (Stainless Steel Actuator): BPO1400N

1 Features of Actuator

Actuator excellent in corrosion-proof and cleaning performances

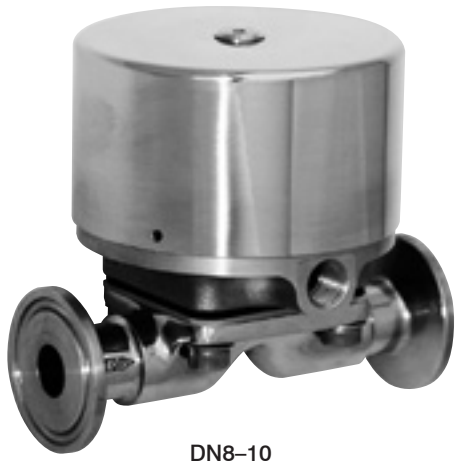

DN8-10



DN15-50

Excellent Corrosion-Proof Performance / All Stainless Steel

- Exposed surfaces are all made of stainless steel. More excellent in corrosion proof performance compared to standard aluminum actuator (BPO1400NB(N)).
- No requirement for coating prevents the occurrence of foreign substances due to peeling of coated films.

Excellent Cleanability / External Shape

- A retaining ring is adopted for fixing the bonnet and cylinder similarly as standard aluminum actuator (BPO1400NB).
- Compactness & buffing, excellent in cleanability.

Significantly Enhanced Smoothness of Action and Durability

- The adopted outer wear ring for piston and bearing* for spindle sliding zone have significantly enhanced the smoothness of action and durability. (* Excluding actuator code 05S)

Actuator Specifications

| | |
|---|---|
| Types | BPO (BPC, BPN) 1400N |
| Actuator Code | 05S, 07S, 09S, 12S, 16S |
| Types of Operation | Single Acting: Reverse Acting BPO (Air to Open / Spring to Close), Direct Acting BPC (Air to Close / Spring to Open), Double Acting: BPN (Air to Open / Air to Close) |
| Nominal Size (DN) | 8-50 |
| Actuator Materials | Cylinder: SCS13 #300 Buffing Bonnet: SCS13 #200 Buffing or Precision Cast Surface |
| Operating Pressure | 0.4 ^{+0.1} MPa • Direct Acting and Double Acting types shall be in accordance with a separate actuator selection table. |
| Max. Shutoff Differential Pressure | 1.0 MPa |
| Lubricants | Cassida Grease HDS2 (Standards regarding food additives: FDA 21 CFR 178.3570. Lubricants with permission of incidental contact with food: NSF Class H1 conforming product) |
| Options | Opening limit device, Special limit switch box (*) |

* Standard ADC12 (Eco-friendly type, white baking finish), Option SCS13A (with #300 Buffing)

Bioclean Diaphragm Valves
Pneumatically Operated ON-OFF Valves

Products for Dead Spaces

Special Valves · Related Products

Sanitary Valves · Clean Room Related Products

Technical Materials

Safety Instructions

2 Actuator Selection Table

Reverse Acting: BPO1400N

Operating Pressure: $0.4^{+0.1}_0$ MPa

| New PTFE Diaphragm | | Working Pressure (MPa) | | | | | | | | | |
|--------------------|----------|------------------------|-----|-----|-----|-----|-----|-----|-----|-----|-----|
| Nominal Size (DN) | Actuator | 0.1 | 0.2 | 0.3 | 0.4 | 0.5 | 0.6 | 0.7 | 0.8 | 0.9 | 1.0 |
| 8 | 05S | | | | | | | | | | |
| 10 | 05S | | | | | | | | | | |
| 15 | 07S | | | | | | | | | | |
| 20 | 09S | | | | | | | | | | |
| 25 | 09S | | | | | | | | | | |
| 40 | 12S | | | | | | | | | | |
| 50 | 16S | | | | | | | | | | |

*Option,

Direct Acting: BPC1400N

Operating Pressure: In table below, MPa
(Operating pressure of 05S: Same as reverse acting)

| New PTFE Diaphragm | | Working Pressure (MPa) | | | | | | | | | |
|--------------------|----------|------------------------|------|-----|-----|-----|-----|------|-----|-----|-----|
| Nominal Size (DN) | Actuator | 0.1 | 0.2 | 0.3 | 0.4 | 0.5 | 0.6 | 0.7 | 0.8 | 0.9 | 1.0 |
| 8 | 05S | | | | | | | | | | |
| 10 | 05S | | | | | | | | | | |
| 15 | 07S | | | | 0.3 | | | 0.35 | | | |
| 20 | 09S | | | | | | | | | | |
| 25 | 09S | | 0.25 | | | 0.3 | | 0.35 | | 0.4 | |
| 40 | 12S | | | | | | | | 0.3 | | |
| 50 | 16S | | | | | | | | | | |

Double Acting: BPN1400N

Operating Pressure: In table below, MPa
(Operating pressure of 05S: Same as reverse acting)

| New PTFE Diaphragm | | Working Pressure (MPa) | | | | | | | | | |
|--------------------|----------|------------------------|------|-----|-----|-----|-----|-----|-----|-----|-----|
| Nominal Size (DN) | Actuator | 0.1 | 0.2 | 0.3 | 0.4 | 0.5 | 0.6 | 0.7 | 0.8 | 0.9 | 1.0 |
| 8 | 05S | | | | | | | | | | |
| 10 | 05S | | | | | | | | | | |
| 15 | 07S | | | | | 0.3 | | | | | |
| 20 | 09S | | | | | | | | | | |
| 25 | 09S | | 0.25 | | | 0.3 | | | | 0.4 | |
| 40 | 12S | | | | | | | | 0.3 | | |
| 50 | 16S | | | | | | | | | | |

3 Major Dimensions

BPO1400N - DN8-10

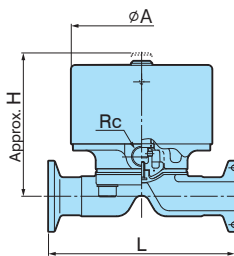

BPO1400N - DN15-50

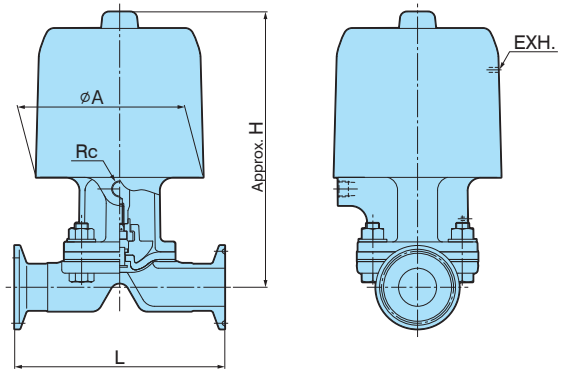

Unit: mm

| Nominal Size | Actuator | L | Approx. H BPO BPC BPN | Rc | phi A | Mass (Approx. kg) | |
|--------------|----------|-----|--------------------------------|-----|-------|----------------------|------|
| | | | | | | BPO | |
| 8 | — | 05S | 90 | 70 | 1/8 | 68 | 1.1 |
| 10 | — | 05S | 90 | 70 | | 68 | 1.1 |
| 15 | — | 07S | 102 | 127 | | 102 | 2.3 |
| 20 | — | 09S | 118 | 155 | | 118 | 3.4 |
| 25 | 1 | 09S | 127 | 168 | | 127 | 3.9 |
| 40 | 1.5 | 12S | 159 | 192 | | 159 | 7.5 |
| 50 | 2 | 16S | 191 | 220 | | 191 | 15.1 |

• The above table is based on Ferrule main body made of SUS316L. Contact us for detailed dimensions for each valve.

2

Bioclean Diaphragm Valve Series

Products for Dead Spaces

2-1. Self-Drain Valves: Type-F

- ① Features of Products
- ② Valve Specifications

2-2. Sampling Valves: Type-P

- ① Features of Products
- ② Valve Specifications
- ③ Major Dimensions

2-3. 3-Way Valves: Type-K

- ① Features of Products
- ② Valve Specifications
- ③ Major Dimensions

2-4. Tank Bottom Valves: Type-T

- ① Features of Products
- ② Valve Specifications
- ③ Major Dimensions

2-1. Self-Drain Valves: Type-F

1 Features of Products

What is the Self-Drain Valve?

- A valve main body with enhanced fluid accumulation prevention effect of Bioclean Diaphragm Valve series.
- This valve has a structure that eliminates the fluid accumulation by horizontally positioning the valve axis when implementing in a horizontal pipeline.



Stainless Steel Main Body: B414 (F)

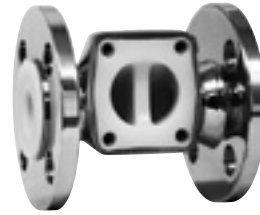

PFA Lined Main Body: B459 (F)

Comparison with Standard Valve Main Body (with valve axis horizontally positioned)

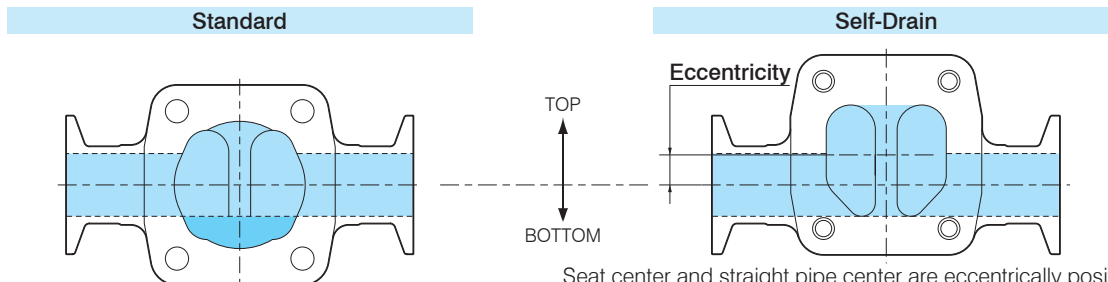

The valve seat is on the same centerline with straight pipe.

Seat center and straight pipe center are eccentrically positioned and the bottom end of valve seat is in line with inner wall of straight pipe.

Example of Applications

For various biotechnology systems, ultra-pure water production system for semiconductor industries and other systems requiring zero liquid accumulation in fluid path

2 Valve Specifications

Stainless Steel

| Manufactured Main Bodies | | | Connection Standard and Manufacturing Range | | | |
|--------------------------|---------------|---------------|---|----------------------|--------------|--------------|
| Name | Main Material | Material Code | Ferrule | Astro (TIG) Welding* | Union Screw* | Flange* |
| | | | Nominal Size | Nominal Size | Nominal Size | Nominal Size |
| Stainless Steel Forged | SUS316L | 14(F) | 8-50 | 8-50 | 8-50 | 8-50 |
| Stainless Steel Cast | SCS16 | 13(F) | 65-100 | 65-100 | 65-100 | 65-100 |

* Option

Lined Main Bodies

| Manufactured Main Bodies | | | Connection Standard and Manufacturing Range |
|--------------------------|---------------|---------------|---|
| Name | Base Material | Material Code | Flange |
| | | | Nominal Size |
| PFA Lining ☆ | SCS13 | 59(F) | 15-50 |

☆: In case of export, export license stipulated in the Foreign Exchange and Foreign Trade Control Law of Japan and/or if necessary, export-related laws and regulations of the United States of America and other countries is required.

Other Specifications

- Main body surface finish classifications, diaphragm specifications, etc., are in accordance with the standard specifications. (Ref. page 10-11)
- Interchangeability with the units for standard main bodies allows the common use with the actuators for manually operated valves and pneumatically operated ON-OFF valves.

Bioclean Diaphragm Valves
 Products for Dead Spaces
 Self-Drain Valves: Type-F
 Special Valves · Related Products
 Sanitary Valves · Clean Room Related Products
 Technical Materials
 Safety Instructions

2-2. Sampling Valves: Type-P

1 Features of Products

- Sampling of fluid without a dead space (pockets or fluid accumulation).
- A compact body that allows a direct implementation in pipeline and the structure with no residual liquid in a valve.
- Applicable for a wide range of applications, such as branching, merging (mixing), introduction of washing water or sterilization steam and discharging, as well as sampling.

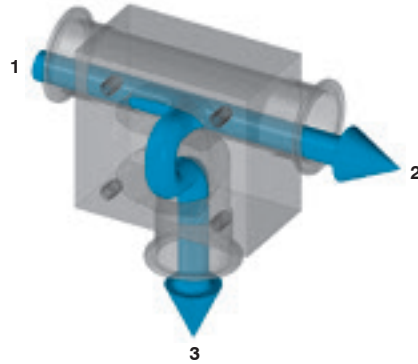

| Valve | Connected Ports | Port No. |
|-------|-------------------------|----------|
| Open | 1 - 2 1 - 3 2 - 3 | |
| Close | 1 - 2 | |

2 Valve Specifications

Standard Specifications

Manufactured Main Bodies

| | |
|---------------------------|---|
| Main Body Material | SUS316L |
| Nominal Size (DN) | Combination of main pipe and valve • Standard: 15–50 (other range supplied as option) |
| Operation Type | Manual operation and pneumatic operation are applicable. |

Other Specifications

- Main body surface finish classifications, diaphragm specifications, etc., are in accordance with the standard specifications. (Ref. page 10–11)
- Interchangeability with the units for standard main bodies allows the common use with the actuators for manually operated valves and pneumatically operated ON-OFF valves.
- PFA coated main body is available. Please contact our sales representative for the details.

3 Major Dimensions (reference)

A typical example is shown with the combination of various nominal sizes and actuators. Please contact us for combinations other than the table below.

Manually Operated Valve: B414 (P) N

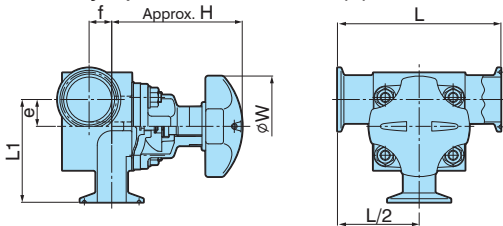

Pneumatically Operated ON-OFF Valve: BPO1414 (P) NB

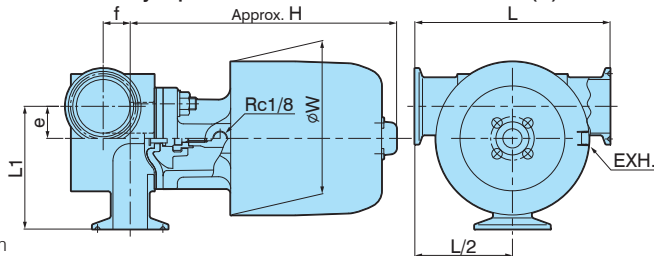

Unit: mm

| Main Pipe × Valve DN (S) | L | L1 | e | f | Manually (B400N) | | Pneumatically ON-OFF (BPO) | | |
|-----------------------------|-----|-------|------|------|------------------|-----|----------------------------|--------------|-----|
| | | | | | Approx. H | W | Actuator | Approx. H | W |
| 15×15 (1S×1S) | 90 | 62.3 | 11.3 | — | 103 | 70 | 07 | 156 | 87 |
| 25×15 (1S×1S) | 100 | 65.0 | 14.0 | 11.0 | 95 | 70 | 07 | 148 | 87 |
| 25×25 (1S×1S) | 130 | 78.5 | 15.0 | — | 114 | 80 | 09 | 188 | 102 |
| 40×15 (1.5S×1S) | 110 | 67.4 | 20.4 | 18.5 | 94 | 70 | 07 | 147 | 87 |
| 40×25 (1.5S×1S) | 130 | 81.8 | 21.4 | 18.0 | 104 | 80 | 09 | 178 | 102 |
| 40×40 (1.5S×1.5S) | 160 | 98.5 | 21.9 | — | 145 | 100 | 12 | 210 | 138 |
| 50×15 (2S×1S) | 120 | 77.4 | 26.4 | 24.0 | 95 | 70 | 07 | 148 | 87 |
| 50×25 (2S×1S) | 140 | 90.9 | 27.4 | 27.0 | 104 | 80 | 09 | 178 | 102 |
| 50×40 (2S×1.5) | 160 | 107.4 | 27.9 | 21.0 | 133 | 100 | 12 | 198 | 138 |
| 50×50 (2S×2S) | 190 | 124.4 | 28.9 | — | 161 | 125 | 16 | 253 | 183 |

2-3. 3-Way Valves: Type-K

1 Features of Products

- Direct installation in a pipeline, compact and a structure with no residual fluid in valve.
- A wide range of application, such as branching, merging (mixing), introduction of washing water and sterilization steam, and discharge.

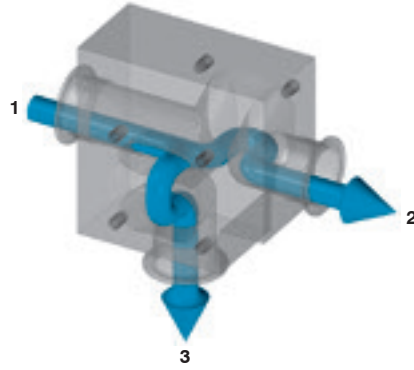

| Valve A | Valve B | Connected Ports | Port No. |
|---------|---------|-------------------------|----------|
| Open | Close | 1 - 2 | |
| Open | Open | 1 - 2 1 - 3 2 - 3 | |
| Close | Open | 1 - 3 | |
| Close | Close | — | |

2 Valve Specifications

Standard Specifications

Manufactured Main Bodies

| | |
|---------------------------|---|
| Main Body Material | SUS316L |
| Nominal Size (DN) | Combination of main pipe and valve • Standard: 15–50 (other range supplied as option) |
| Operation Type | Manual operation and pneumatic operation are applicable. |

Other Specifications

- Main body surface finish classifications, diaphragm specifications, etc., are in accordance with the standard specifications. (Ref. page 10–11)
- Interchangeability with the units for standard main bodies allows the common use with the actuators for manually operated valves and pneumatically operated ON-OFF valves.
- PFA coated main body is available. Please contact our sales representative for the details.

3 Major Dimensions (reference)

A typical example is shown with the combination of various nominal sizes and actuators. Please contact us for combinations other than the table below.

Manually Operated Valve: B414 (K) N

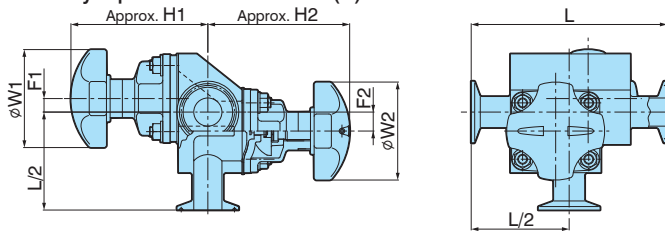

Pneumatically Operated ON-OFF Valve: BPO1414 (K) NB

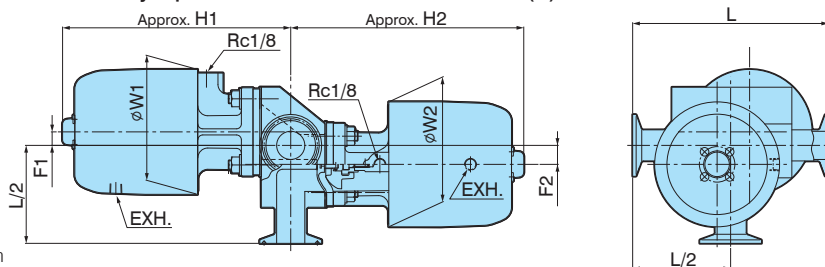

Unit: mm

| Main Pipe × Valve DN (S) | L | F1 | F2 | Manually Operated Valve (B400N) | | | | Pneumatically Operated ON-OFF Valve (BPO) | | | | | |
|--------------------------|-----|------|------|---------------------------------|------------|-----|-----|---|------------|-----|-------------|------------|-----|
| | | | | Approx. H1 | Approx. H2 | W1 | W2 | Actuator: A | Approx. H1 | W1 | Actuator: B | Approx. H2 | W2 |
| 15×15 (1S×1S) | 130 | 5.7 | 11.8 | 103 | 103 | 70 | 70 | 07 | 156 | 87 | 07 | 156 | 87 |
| 25×15 (1S×1S) | 160 | 11.0 | 14.5 | 112 | 109 | 80 | 70 | 09 | 186 | 102 | 07 | 162 | 87 |
| 25×25 (1S×1S) | 160 | 11.0 | 15.5 | 112 | 116 | 80 | 80 | 09 | 186 | 102 | 09 | 190 | 102 |
| 40×15 (1.5S×1S) | 200 | 14.7 | 20.9 | 142 | 114 | 100 | 70 | 12 | 207 | 138 | 07 | 167 | 87 |
| 40×25 (1.5S×1S) | 200 | 14.7 | 21.9 | 142 | 125 | 100 | 80 | 12 | 207 | 138 | 09 | 199 | 102 |
| 40×40 (1.5S×1.5S) | 200 | 14.7 | 21.9 | 145 | 147 | 100 | 100 | 12 | 209 | 138 | 12 | 211 | 138 |
| 50×15 (2S×1S) | 230 | 14.0 | 26.9 | 154 | 117 | 125 | 70 | 16 | 246 | 183 | 07 | 170 | 87 |
| 50×25 (2S×1S) | 230 | 14.0 | 27.9 | 154 | 130 | 125 | 80 | 16 | 246 | 183 | 09 | 204 | 102 |
| 50×40 (2S×1.5) | 230 | 14.0 | 27.9 | 154 | 155 | 125 | 100 | 16 | 246 | 183 | 12 | 220 | 138 |
| 50×50 (2S×2S) | 230 | 14.0 | 28.4 | 154 | 164 | 125 | 125 | 16 | 246 | 183 | 16 | 256 | 183 |

2-4. Tank Bottom Valves: Type-T

1 Features of Products

- Excellent agitation efficiency with direct welding on tank bottom
- No gland packing, stem, seat, gasket, etc., at contacting zone with liquid, and the open/close operation only by diaphragm will facilitate smooth discharge of tank contents with almost no residues. Extremely low contamination attributable to valve parts, and the washing and sterilization are easy and secure.
- A wide range of nominal size from DN15 to 100 (4S) facilitates the application from small container of 10 L to a medium size tank of 10,000 L.



Installation

2 Valve Specifications

Standard Specifications

Manufactured Main Bodies

| | |
|---------------------------|--|
| Main Body Material | SUS316L |
| Nominal Size (DN) | 15–100 |
| Operation Type | Manual operation and pneumatic operation are applicable. |
| Option | Flange connection, Branch pipe, etc. |

Other Specifications

- Main body surface finish classifications, diaphragm specifications, etc., are in accordance with the standard specifications. (Ref. page 10–11)
- Interchangeability with the units for standard main bodies allows the common use with the actuators for manually operated valves and pneumatically operated ON-OFF valves.

3 Major Dimensions (reference)

typical example is shown with the combination of various actuators. Please contact us for combinations other than the table below.

Manually Operated Valve: B414 (T) N

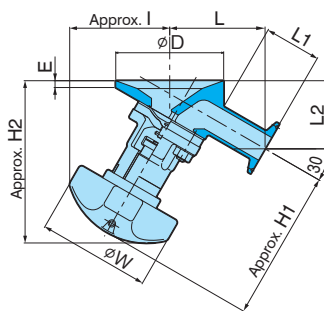

Pneumatically Operated ON-OFF Valve: BPO1414 (T) NB

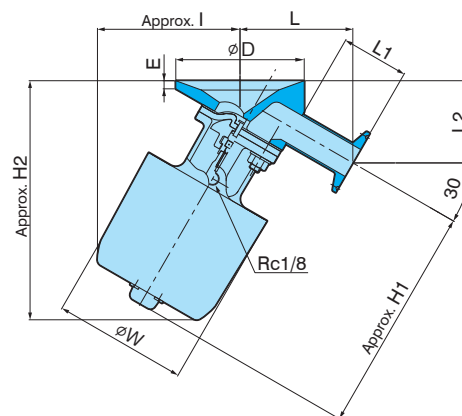

Unit: mm

| Nominal Size DN (S) | L | L1 | L2 | D | E | Manually Operated Valve (B400N) | | | | | Pneumatically Operated ON-OFF Valve (BPO) | | | | | |
|------------------------|-----|----|-----|-----|----|---------------------------------|---------------|--------------|-----|----------------------|---|---------------|---------------|--------------|-----|----------------------|
| | | | | | | Approx. H1 | Approx. H2 | Approx. I | W | Mass (Approx. kg) | Actuator | Approx. H1 | Approx. H2 | Approx. I | W | Mass (Approx. kg) |
| 15 | 73 | 50 | 59 | 69 | 14 | 96 | 112 | 63 | 70 | 1.5 | 07 | 148 | 156 | 84 | 87 | 1.5 |
| 20 | 76 | 50 | 60 | 80 | 12 | 100 | 113 | 67 | 70 | 2.0 | 09 | 166 | 173 | 103 | 102 | 2.3 |
| 25 (1S) | 84 | 50 | 60 | 95 | 6 | 106 | 119 | 70 | 80 | 2.5 | 09 | 180 | 184 | 105 | 102 | 2.8 |
| 40 (1.5S) | 103 | 50 | 68 | 139 | 6 | 137 | 149 | 86 | 70 | 4.5 | 12 | 203 | 214 | 126 | 138 | 5.6 |
| 50 (2S) | 129 | 63 | 83 | 177 | 6 | 154 | 169 | 99 | 80 | 7.0 | 16 | 247 | 261 | 154 | 183 | 10.0 |
| 65 (2.5S) | 140 | 63 | 90 | 204 | 12 | 182 | 212 | 107 | 100 | 11.0 | 16BN* | 299 | 300 | 166 | 194 | 16.0 |
| | | | | | | | | | | | 20BN* | 350 | 347 | 199 | 236 | 22.0 |
| 80 (3S) | 152 | 63 | 105 | 254 | 12 | 200 | 243 | 131 | 70 | 17.0 | 20BN* | 369 | 370 | 209 | 236 | 27.2 |
| | | | | | | | | | | | 25BN* | 407 | 404 | 248 | 286 | 40.6 |
| 100 (4S) | 179 | 63 | 153 | 301 | 12 | 263 | 325 | 193 | 80 | 22.0 | 20BN* | 387 | 407 | 242 | 236 | 36.4 |
| | | | | | | | | | | | 25BN* | 425 | 438 | 274 | 286 | 49.8 |

* BPO1400N

Memo

A series of horizontal dotted lines for writing.

3

Bioclean Diaphragm Valve Series

Special Valves · Related Products

3-1. Branch Valves

- ① Features of Products
- ② Valve Specifications
- ③ Major Dimensions
- ④ Combination Pattern Diagrams

3-2. Combination Valves, Multi-Branch Valves

- ① Combination Valves
- ② Multi-Branch Valves

3-3. Other Related Products

- ① Ferrule Connection Corrosion-Proof Valves
- ② Two Stage Open/Close Actuator
- ③ Steam Trap Substituting Valves

3-1. Branch Valves

1 Features of Products

- The combination valves with vertically/horizontally-branched valves (or pipes) on the position with no liquid accumulation of main valve
- Available for a wide range of applications, such as branching, merging, sampling, and introduction of sterilization steam.
- The simple structure branch valve (or pipe) combination has a higher cost benefit compared to conventional sampling valves or 3-way valves. (Pay attention on dead space generated between main valve and branch valve from structural reason)

Horizontal main valve / vertical branch valve



2 Valve Specifications

Standard Specifications

Manufactured Main Bodies

| | |
|---------------------------|--|
| Main Body Material | SUS316L |
| Nominal Size (DN) | Combination of main pipe and valve • Standard: 15–50 (other range supplied as an option) |
| Operation Type | Manual operation and pneumatic operation are applicable. |

Other Specifications

- Main body surface finish classifications, diaphragm specifications, etc., are in accordance with the standard specifications. (Ref. page 10–11)
- Interchangeability with the units for standard main bodies allows the common use with the various actuators for manually operated valves and pneumatically operated ON-OFF valves.

3 Major Dimensions (reference)

A reference example is shown below for horizontal main valve with vertical branch valve. The combination of various mounting pattern, nominal size, operation type, etc., is manufactured as requested. (Please refer to the next page for details of mounting patterns.)

| Valve A | Valve B | Connected Ports | Port No. Diagram |
|---------|---------|-------------------------|------------------|
| Open | Close | 1 - 2 | |
| Open | Open | 1 - 2 2 - 3 1 - 3 | |
| Close | Open | 2 - 3 | |
| Close | Close | — | |



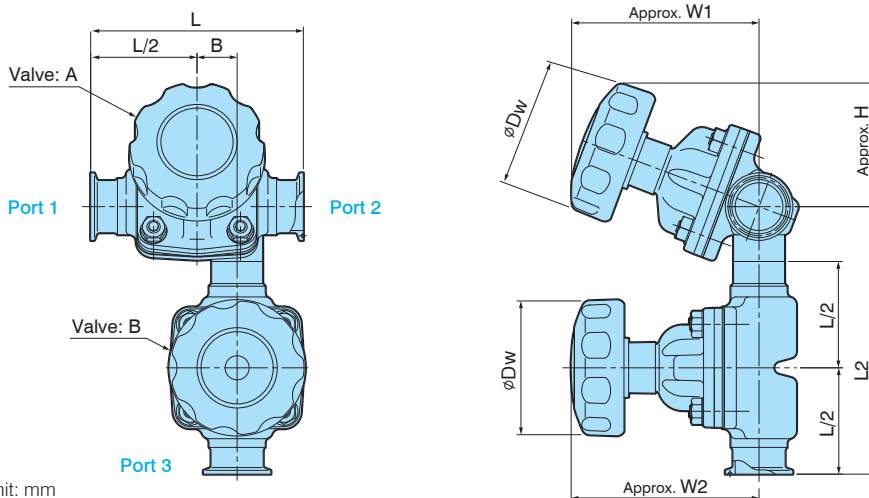





Manually Operated Valve: BC414 (A)







Unit: mm

| Nominal Size DN (S) | L | L2 | Dw | B | W1 | W2 | H |
|---------------------|-----|-----|-----|------|-----|-----|-----|
| 15 | 102 | 145 | 63 | 16.0 | 92 | 89 | 51 |
| 20 | 118 | 165 | | 18.5 | 100 | 98 | |
| 25 (1S) | 127 | 200 | 80 | 19.0 | 113 | 112 | 75 |
| 40 (1.5S) | 159 | | 100 | 30.0 | 141 | 141 | 92 |
| 50 (2S) | 191 | | 125 | 35.5 | 168 | 169 | 103 |





1 Branch Valves (Horizontal Main Valve)

| Branch Valve Position | Right Side | | Left Side | |
|--|---|---|--|---|
| Branch Valve Direction | Front | Back | Front | Back |
| Main Valve: Horizontal Branch Valve: Vertical |  A |  B |  C |  D |
| Main Valve: Horizontal Branch Valve: Horizontal |  E |  F |  G |  H |

2 Branch Valves (Vertical Main Valve)

| Branch Valve Position | Upper Side | | Lower Side | |
|--|--|--|---|--|
| Branch Valve Direction | Front | Back | Front | Back |
| Main Valve: Vertical Branch Valve: Horizontal |  I |  J |  K |  L |

3 Branch Valves (Horizontal Main Valve)

| Branch Valve Position | Right Side | | Left Side | |
|---|---|------|--|------|
| Branch Valve Direction | Front | Back | Front | Back |
| Main Valve: Horizontal Branch Pipe: Vertical |  R | — |  S | — |
| Main Valve: Horizontal Branch Pipe: Horizontal |  T | — |  U | — |

4 Branch Valve (Vertical Main Valve)

| Branch Valve Position | Upper Side | | Lower Side | |
|--|---|------|------------|------|
| Branch Valve Direction | Front | Back | Front | Back |
| Main Valve: Vertical Branch Valve: Horizontal |  V | — | — | — |

3-2. Combination Valves, Multi-Branch Valves

1 Combination Valves

The following requests are responded through the manufacturing of combination valves. Please contact our sales dept. or local representative for a detailed study.

- Separation or merging of flow is required, but shall be as compact as possible
- Integration of multiple valves is required for compactification.
- A countermeasure for dead spaces in various processes is required.
- Reduction of retained water is required with an installation in a special posture.

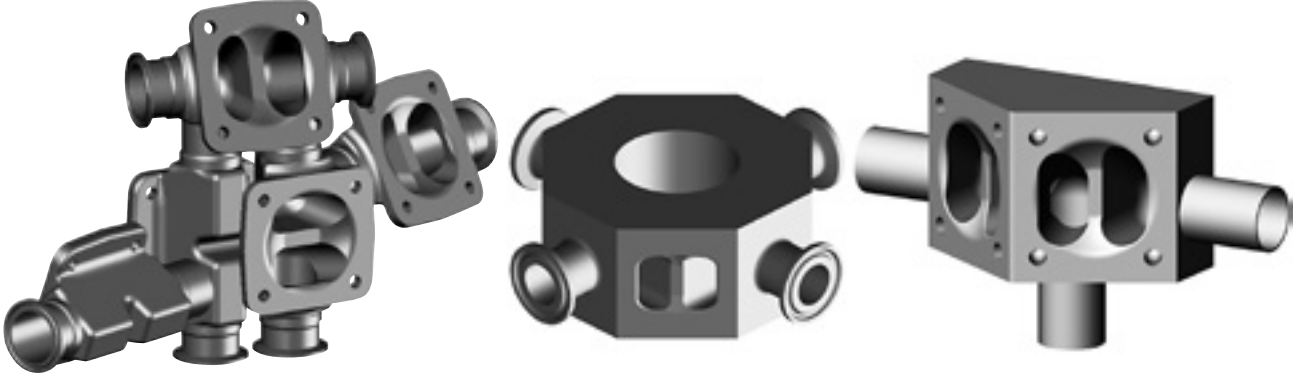

2 Multi-Branch Valves

- A combination of a number of valves is integrated into a compact main body with branched and merged functions.
- The number of ports are designed and manufactured to the request.
- The interchangeability of actuator with standard main bodies allows the use for both manually and pneumatically operated valves.

Example of 6 Port Valve: Branching in 6 directions or merging from 6 directions

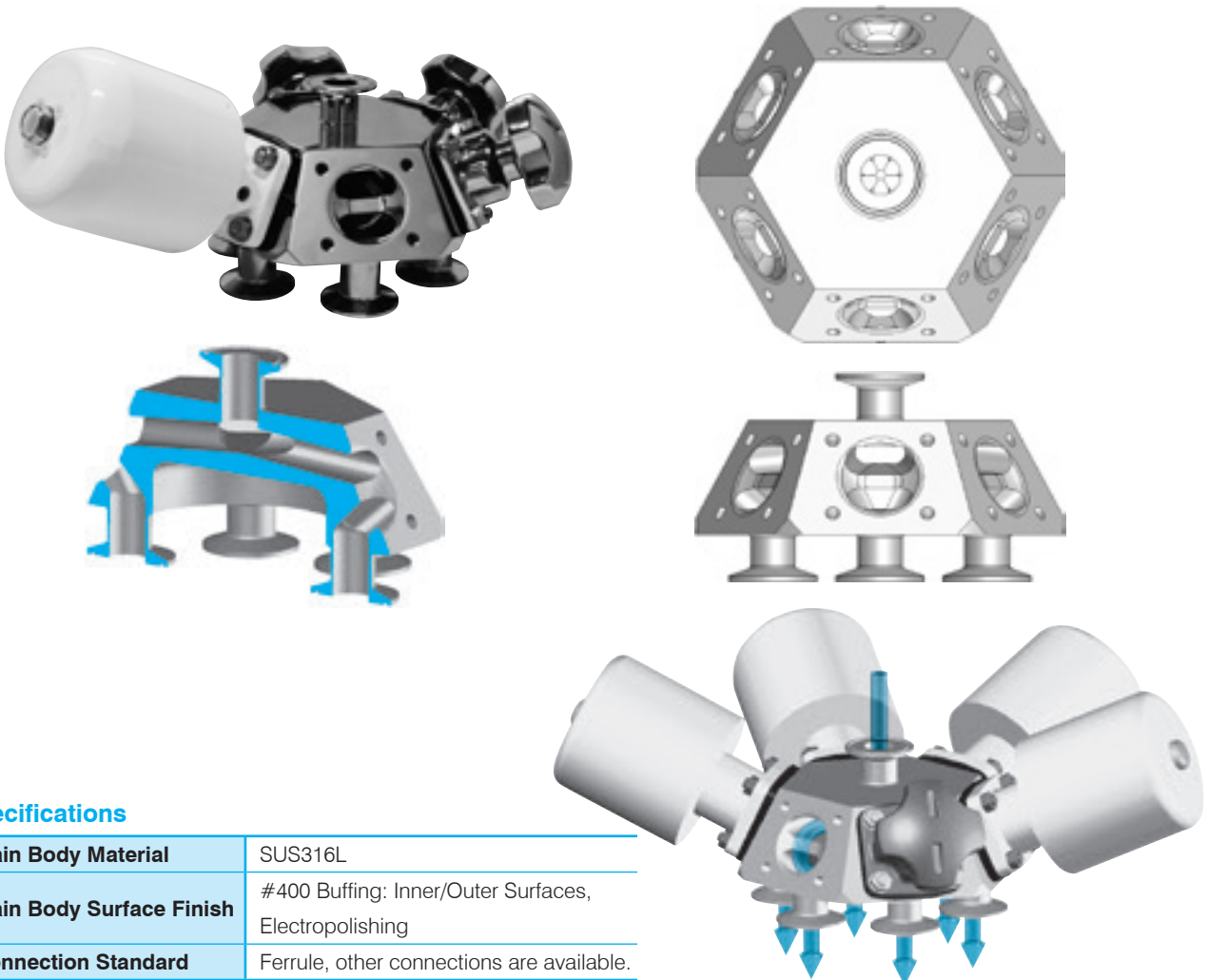

Specifications

| | |
|---------------------------------|---|
| Main Body Material | SUS316L |
| Main Body Surface Finish | #400 Buffing: Inner/Outer Surfaces, Electropolishing |
| Connection Standard | Ferrule, other connections are available. |

3-3. Other Related Products

1 Ferrule Connection Corrosion-Proof Valves

① Fluororesin (ETFE) Lined Main Body

The optimum main bodies as the countermeasures for corrosive fluids, crevice corrosion by Cl^- ion and elution of metal ions for sanitary piping.

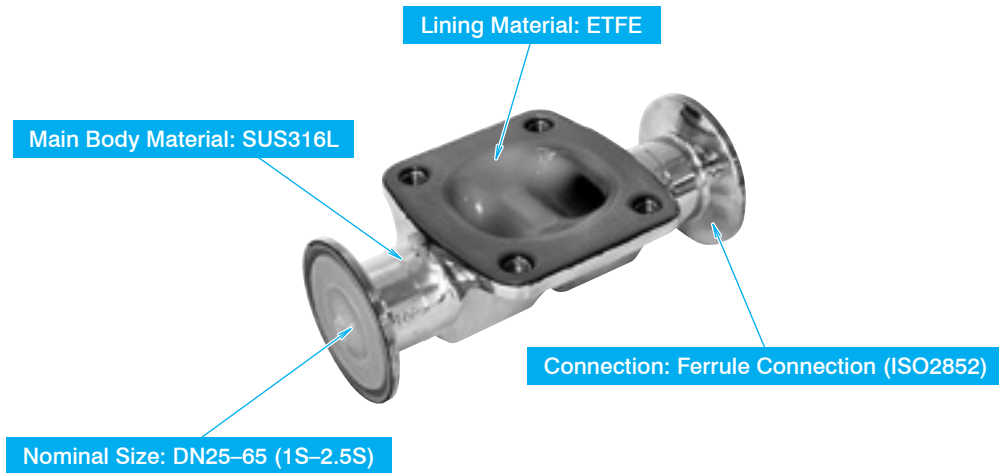

Features of Product

- Fluororesin (ETFE) lining is corrosion proof to strong acids, inorganic alkali, halogens, and metal salt solutions.
- Compared to special alloy materials, such as expensive duplex stainless steel, generally better in cost performance.
- Adoption of rotational molding process for acquiring strong adhesion of lining on the metal body eliminates the lifting or swelling of lining for the high temperature vacuum specifications.
- The joints and gaskets in market can be used.
- Max. Working Temperature: 120 °C

② Fluororesin (PFA) Coated Main Body



Features of Product

- Various PFA coatings can be applied. The coating materials can be selected depending on the user's purpose, such as corrosion resistance, non-adhesiveness, antistatic, etc.
- Commercially available fittings and gaskets can be used.
- In addition to standard 2-way valves, it can be applied to a wide range of body types, such as sampling valves, 3-way valves, and other dead space countermeasure products, as well as flange-type bodies. Please contact our sales department for more details.

2 Two Stage Open/Close Actuator

Features of Products

- Non-step valve position adjustment is available.
- Extensive track records as filling valves for pharmaceuticals and potable water, etc.
- Interchangeable with various main bodies of bioclean diaphragm valves.
- The adjusting range for medium opening: 0–30%

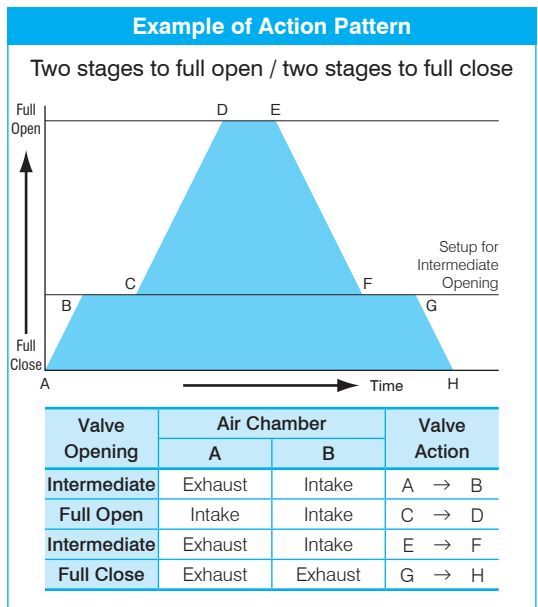
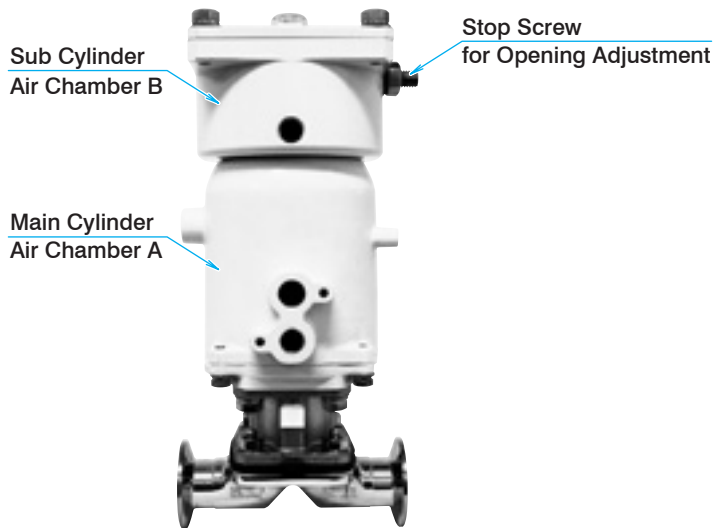

- Patterns "one stage to full open / two stages to full close" and "two stages to full open / one stage to full close" are available as well.

3 Steam Trap Substituting Valves

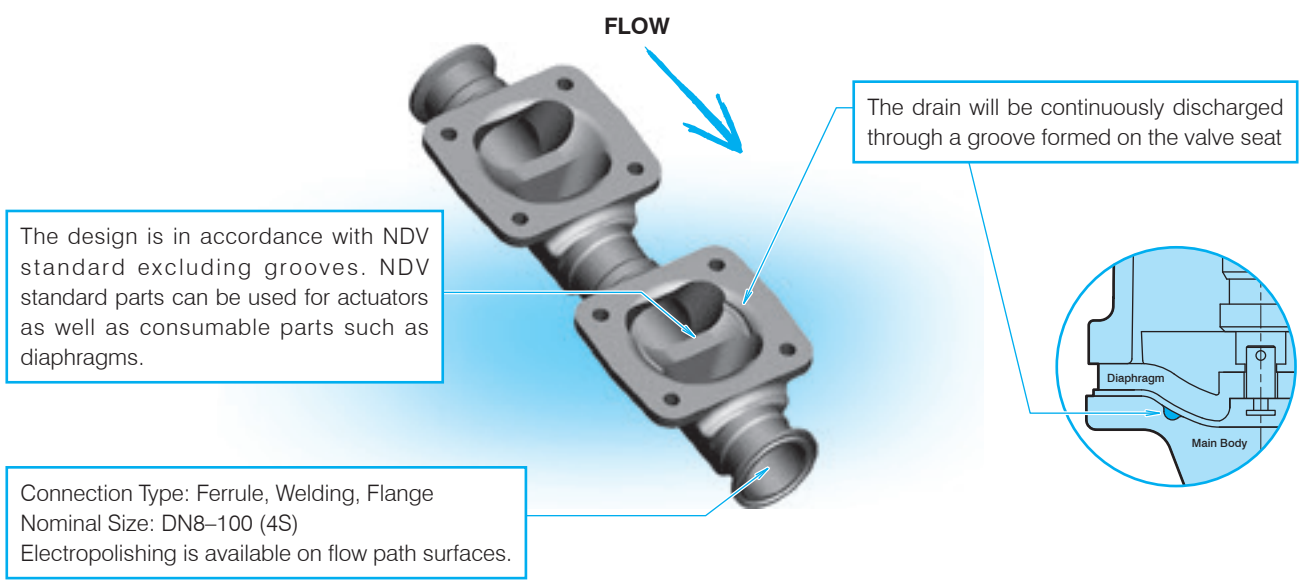

Features of Products

- Simple design drain discharge valve for sanitary piping.
- Application of bioclean diaphragm valve; an optimum solution for various manufacturing equipment, such as medical drugs, cosmetics, foods and semiconductors.
- Diaphragm valve continuously draining through a small hole on the valve seat predesigned to the predicted drain quantity; an idea that did not exist in conventional steam trap. The combination of this product and our standard diaphragm valve will configure a clean and stable draining system.
- The simple configuration eliminating bypass piping can reduce the chance of pollution.
- The basic structure of the diaphragm valve can avoid immediate failure even when foreign substances enter the valve seat and can provide excellent maintainability.

Response to the customer's needs through a made to order system is the strength of our company. Please feel free to contact us for any requests regarding options for various operation devices and special shape of main bodies or special materials.

4

Sanitary Valves · Clean Room Related Products

4-1. Sanitary Ball Valves

- ① Product Specifications
- ② Major Dimensions

4-2. Sanitary Check Valves

- ① Product Specifications
- ② Major Dimensions

4-3. Sanitary Butterfly Valves

- ① Product Specifications
- ② Major Dimensions

4-4. Powder & Granule / Tablet Discharge Valves

- ① [Powder & Granular Product Discharging] Sanitary Butterfly Valves
- ② [Tablet Discharging] Sanitary Dampers

4-5. Ultra-High Airtight Dampers

- ① Features of Products
- ② Product Specifications
- ③ Actuator Selection Table
- ④ Major Dimensions

4-1. Sanitary Ball Valves

1 Product Specifications

2BM: 2-Way Ball Valve / BN3-M: 3-Way Ball Valve

| | |
|--|--|
| Fluid Contacting Parts Material | SUS316L |
| Seat Material | PTFE |
| Packing Material | Standard: Fluorine Rubber Option: EPDM, Silicon Rubber, NBR |
| Surface Finish | Inside: #320–400 Buffing Outside: #320–400 Buffing |
| Working Temperature Range | –5 to 95 °C (NBR: –5 to 80 °C) |
| Connection Standard | Ferrule Screw in accordance with ISO standard |
| Max. Working Pressure | 0.7 MPa |
| Pneumatic Operating Pressure | 0.4 MPa (max 0.7 MPa) |

2BV-M: Small Diameter 2-Way Ball Valve

| | |
|--|--|
| Fluid Contacting Parts Material | SUS316L |
| Seat Material | PTFE |
| Surface Finish | Inside: #400 Buffing Outside: Hairline Finish |
| Working Temperature Range | 0 to 95 °C |
| Connection Standard | Ferrule Screw in accordance with ISO standard |
| Max. Working Pressure | 0.7 MPa |

2 Major Dimensions

2BM: Manually Operated 2-Way Ball Valve

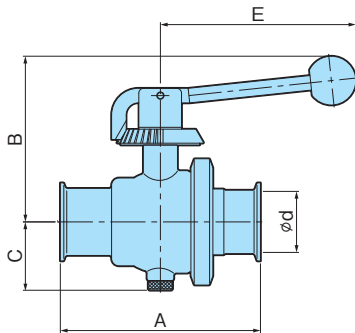

Unit: mm

| Nominal Size (DN) | 25 (1S) | 40 (1.5S) | 50 (2S) | 65 (2.5S) | 80 (3S) | 90 (3.5S) | 100 (4S) |
|-------------------|---------|-----------|---------|-----------|---------|-----------|----------|
| d | 23 | 35.7 | 47.8 | 59.5 | 72.3 | 85.1 | 97.6 |
| A | 110 | 140 | 164 | 210 | 220 | 250 | 310 |
| B | 100 | 107 | 135 | 145 | 175 | 184 | 195 |
| C | 39 | 48 | 56 | 71 | 83 | 93.5 | 104 |
| E | 150 | 150 | 160 | 160 | 207 | 207 | 207 |

Remarks: Resin (ABS) handle for 1S–1.5S, SUS handle for 2S and above

BN3-M: Manually Operated 3-Way Ball Valve

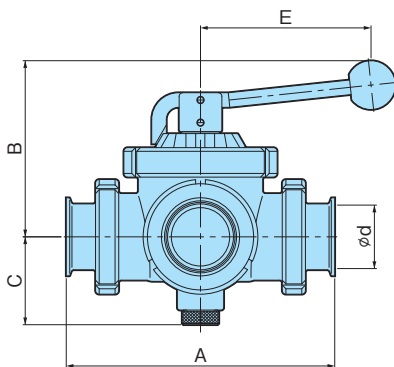

Unit: mm

| Nominal Size (DN) | 25 (1S) | 40 (1.5S) | 50 (2S) | 65 (2.5S) | 80 (3S) | 90 (3.5S) | 100 (4S) |
|-------------------|---------|-----------|---------|-----------|---------|-----------|----------|
| d | 23 | 35.7 | 47.8 | 59.5 | 72.3 | 85.1 | 97.6 |
| A | 170 | 190 | 220 | 240 | 260 | 300 | 310 |
| B | 130 | 134 | 144 | 173 | 189 | 207 | 215 |
| C | 53 | 59 | 72 | 93 | 99 | 111 | 116 |
| E | 160 | 160 | 160 | 207 | 207 | 277 | 277 |

2BV-M: Small Diameter Manually Operated 2-Way Ball Valve

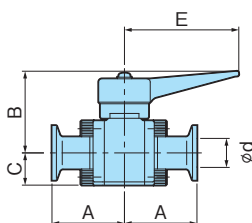

Unit: mm

| Nominal Size (DN) | 8 | 10 | 15 |
|-------------------|------|----|------|
| d | 10.5 | 14 | 17.5 |
| A | 45 | 45 | 45 |
| B | 51 | 51 | 54 |
| C | 20 | 20 | 23 |
| E | 70 | 70 | 70 |

2BM-PW: Pneumatically Operated 2-Way Ball Valve (Double Acting)

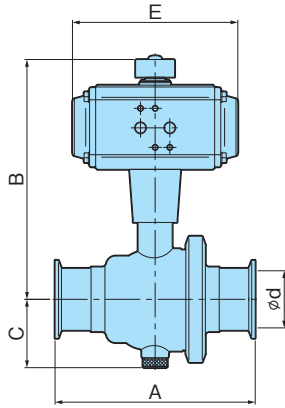

Unit: mm

| Nominal Size (DN) | 25 (1S) | 40 (1.5S) | 50 (2S) | 65 (2.5S) | 80 (3S) | 90 (3.5S) | 100 (4S) |
|-------------------|---------|-----------|---------|-----------|---------|-----------|----------|
| d | 23 | 35.7 | 47.8 | 59.5 | 72.3 | 85.1 | 97.6 |
| A | 110 | 140 | 164 | 210 | 220 | 250 | 310 |
| B | 183 | 190 | 199 | 229 | 253 | 262 | 290 |
| C | 39 | 48 | 56 | 71 | 83 | 93 | 103 |
| E | 136 | 136 | 136 | 154 | 154 | 154 | 204 |

2BM-PW: Pneumatically Operated 2-Way Ball Valve (Single Acting)

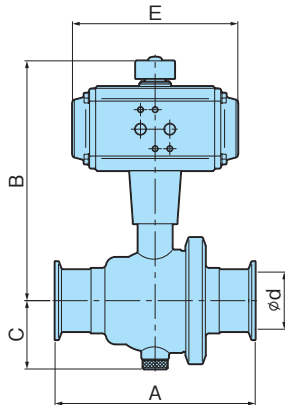

Unit: mm

| Nominal Size (DN) | 25 (1S) | 40 (1.5S) | 50 (2S) | 65 (2.5S) | 80 (3S) | 90 (3.5S) | 100 (4S) |
|-------------------|---------|-----------|---------|-----------|---------|-----------|----------|
| d | 23 | 35.7 | 47.8 | 59.5 | 72.3 | 85.1 | 97.6 |
| A | 110 | 140 | 164 | 210 | 220 | 250 | 310 |
| B | 183 | 190 | 219 | 229 | 270 | 279 | 290 |
| C | 39 | 48 | 56 | 71 | 83 | 93 | 103 |
| E | 136 | 136 | 154 | 154 | 204 | 204 | 204 |

2BM-PS: Pneumatically Operated 2-Way Ball Valve (Double Acting)

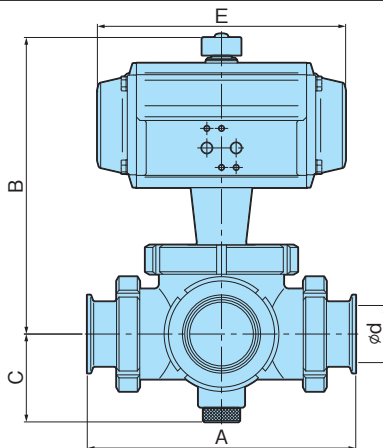

Unit: mm

| Nominal Size (DN) | 25 (1S) | 40 (1.5S) | 50 (2S) | 65 (2.5S) | 80 (3S) | 90 (3.5S) | 100 (4S) |
|-------------------|---------|-----------|---------|-----------|---------|-----------|----------|
| d | 23 | 35.7 | 47.8 | 59.5 | 72.3 | 85.1 | 97.6 |
| A | 170 | 190 | 220 | 240 | 260 | 300 | 310 |
| B | 215 | 219 | 246 | 268 | 284 | 319 | 327 |
| C | 53 | 59 | 72 | 93 | 99 | 111 | 116 |
| E | 154 | 154 | 204 | 204 | 204 | 269 | 269 |

BN3-PS: Pneumatically Operated 3-Way Ball Valve (Single Acting)

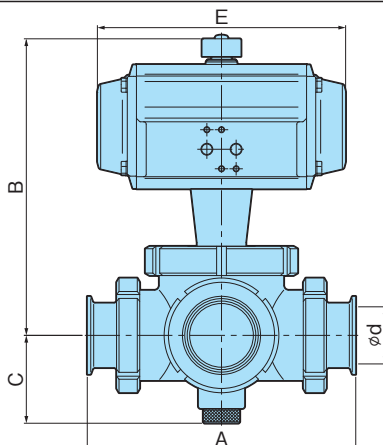

Unit: mm

| Nominal Size (DN) | 25 (1S) | 40 (1.5S) | 50 (2S) | 65 (2.5S) | 80 (3S) | 90 (3.5S) | 100 (4S) |
|-------------------|---------|-----------|---------|-----------|---------|-----------|----------|
| d | 23 | 35.7 | 47.8 | 59.5 | 72.3 | 85.1 | 97.6 |
| A | 170 | 190 | 220 | 240 | 260 | 300 | 310 |
| B | 232 | 236 | 276 | 293 | 309 | 359 | 406 |
| C | 53 | 59 | 72 | 93 | 99 | 111 | 116 |
| E | 204 | 204 | 269 | 269 | 269 | 345 | 438 |

2BM-E: Electrically Operated 2-Way Ball Valve

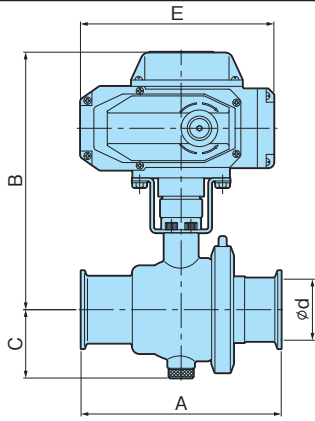

Unit: mm

| Nominal Size (DN) | 25 (1S) | 40 (1.5S) | 50 (2S) | 65 (2.5S) | 80 (3S) | 90 (3.5S) | 100 (4S) |
|-------------------|---------|-----------|---------|-----------|---------|-----------|----------|
| d | 23 | 35.7 | 47.8 | 59.5 | 72.3 | 85.1 | 97.6 |
| A | 110 | 140 | 164 | 210 | 220 | 250 | 310 |
| B | 195 | 202 | 211 | 221 | 276 | 285 | 295 |
| C | 39 | 48 | 56 | 71 | 83 | 93.5 | 104 |
| E | 159 | 159 | 159 | 159 | 159 | 159 | 208 |

BN3-E: Electrically Operated 3-Way Ball Valve

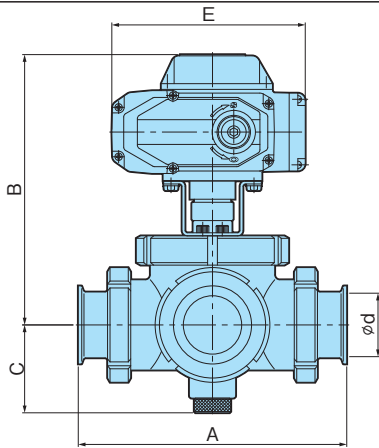

Unit: mm

| Nominal Size (DN) | 25 (1S) | 40 (1.5S) | 50 (2S) | 65 (2.5S) | 80 (3S) |
|-------------------|---------|-----------|---------|-----------|---------|
| d | 23 | 35.7 | 47.8 | 59.5 | 72.3 |
| A | 170 | 190 | 220 | 240 | 260 |
| B | 207 | 211 | 221 | 274 | 290 |
| C | 53 | 59 | 72 | 93 | 99 |
| E | 159 | 159 | 159 | 208 | 208 |

4-2. Sanitary Check Valves

1 Product Specifications

Lift-catch type check valves (non-return valve). Eccentric types and drain nozzle types are prepared as well. Clamp-type mounting of main body provides ease of disassembling/assembling and is excellent in maintenance.

| | |
|-----------------------------------|--|
| Cracking Pressure | 0.01 MPa |
| Max. Working Pressure | 0.5 MPa |
| Surface Finish | Inside: #320–400 Buffing Outside: Shot Finish |
| Ordinary Temperature Range | –5 to 100 °C (Standard seal material: Fluorine Rubber) |
| Connection Standard | Ferrule Screw in accordance with ISO standard |
| Max. Working Pressure | 0.5 MPa |

2 Major Dimensions

DV: Check Valve

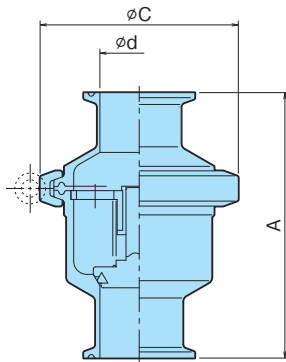

Unit: mm

| Nominal Size (DN) | 8 | 10 | 15 | 25 (1S) | 40 (1.5S) | 50 (2S) | 65 (2.5S) | 80 (3S) | 90 (3.5S) | 100 (4S) |
|-------------------|------|-----|------|---------|-----------|---------|-----------|---------|-----------|----------|
| d | 10.5 | 14 | 17.5 | 23.0 | 35.7 | 47.8 | 59.5 | 72.3 | 85.1 | 97.6 |
| A | 100 | 100 | 100 | 110 | 120 | 130 | 140 | 145 | 170 | 200 |
| C | 63 | 63 | 63 | 77 | 90 | 119 | 132 | 143 | 174 | 202 |
| Mass (kg) | | | 0.55 | 0.85 | 1.2 | 2.0 | 2.7 | 3.3 | 4.8 | 6.5 |

HV: Eccentric Check Valve

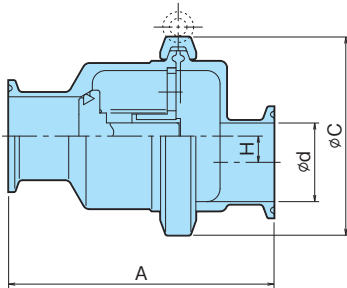

Unit: mm

| Nominal Size (DN) | 8 | 10 | 15 | 25 (1S) | 40 (1.5S) | 50 (2S) | 65 (2.5S) | 80 (3S) |
|-------------------|------|-------|------|---------|-----------|---------|-----------|---------|
| d | 10.5 | 14 | 17.5 | 23.0 | 35.7 | 47.8 | 59.5 | 72.3 |
| A | 100 | 100 | 100 | 110 | 120 | 130 | 140 | 145 |
| C | 63 | 63 | 63 | 77 | 90 | 119 | 132 | 143 |
| H | 12.6 | 10.85 | 9.1 | 12.4 | 11.9 | 18.65 | 19.05 | 18.0 |
| Mass (kg) | | | 0.55 | 0.85 | 1.2 | 2.0 | 2.7 | 3.3 |

HNV: Eccentric Check Valve (with Drain Nozzle)

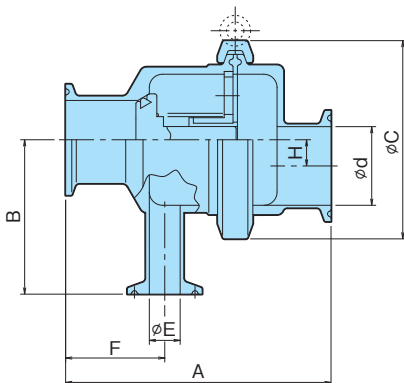

Unit: mm

| Nominal Size (DN) | 25 (1S) | 40 (1.5S) | 50 (2S) | 65 (2.5S) | 80 (3S) |
|-------------------|---------|-----------|---------|-----------|---------|
| d | 23.0 | 35.7 | 47.8 | 59.5 | 72.3 |
| A | 110 | 120 | 130 | 140 | 145 |
| B | 55 | 70 | 82 | 90 | 95 |
| C | 77 | 90 | 119 | 132 | 143 |
| E | 14 | 14 | 23 | 23 | 23 |
| F | 44 | 45.0 | 51.5 | 52.5 | 54.5 |
| H | 12.4 | 11.9 | 18.65 | 19.05 | 18.0 |
| Mass (kg) | 0.95 | 1.3 | 2.1 | 2.8 | 3.4 |

4-3. Sanitary Butterfly Valves

1 Product Specifications

RB series butterfly valves are compactly designed to lightweight pursuing cleanliness in accordance with ISO standard. The features of manual valves are the lightness of operation with extremely low operation torque and low flow resistance when fully opened. There are EPDM materials in accordance with FDA standard and silicon rubbers conforming to Food Sanitation Act for seat ring materials, and can be selected in accordance with the conditions for use.

| | |
|--|---|
| Fluid Contacting Parts Material | SUS316L |
| Seat Ring Material | Standard: EPDM, Thermal durability -5 to 95 °C (125 °C, 30 min, once a day, with no-operation) Option: Silicon Rubber (Please contact us for specifications) |
| Surface Finish | Inside: #320-400 Buffing Outside: Shot Finish |
| Connection Standard | Ferrule Screw in accordance with ISO standard |
| Max. Working Pressure | 0.7 MPa |

2 Major Dimensions

RB-MS: Manually Operated Butterfly Valves

There are 7 stoppers with lock (0°, 15°, 30°, 45°, 60°, 75°, 90°) in the direction from full open to full close for position setting of valve for adjusting the valve position. If fine adjustments are required, an adjustable stopper (option) can be attached for non-step adjustment of position.

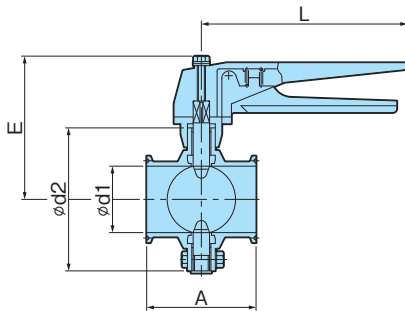

Unit: mm

| Nominal Size (DN) | 25 (1S) | 40 (1.5S) | 50 (2S) | 65 (2.5S) | 80 (3S) | 100 (4S) |
|-------------------|---------|-----------|---------|-----------|---------|----------|
| d1 | 23 | 35.7 | 47.8 | 59.5 | 72.3 | 97.6 |
| d2 | 77 | 91 | 104 | 126 | 126 | 150 |
| A | 80 | 80 | 80 | 100 | 100 | 125 |
| E | 92 | 99 | 106 | 120 | 120 | 133 |
| L | 150 | 150 | 150 | 150 | 150 | 150 |

RB-PW: Pneumatically Operated Butterfly Valves (Double Acting)

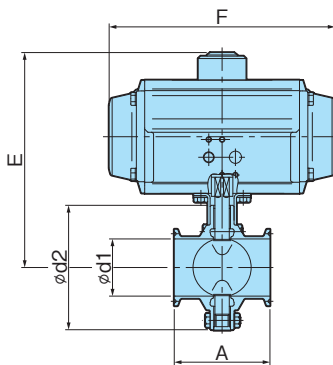

Unit: mm

| Nominal Size (DN) | 25 (1S) | 40 (1.5S) | 50 (2S) | 65 (2.5S) | 80 (3S) | 100 (4S) |
|-------------------|---------|-----------|---------|-----------|---------|----------|
| d1 | 23 | 35.7 | 47.8 | 59.5 | 72.3 | 97.6 |
| d2 | 77 | 91 | 104 | 126 | 126 | 150 |
| A | 80 | 80 | 80 | 100 | 100 | 125 |
| E | 142 | 149 | 170 | 184 | 198 | 210 |
| F | 136 | 136 | 154 | 154 | 204 | 204 |

RB-PS: Pneumatically Operated Butterfly Valves (Single Acting)

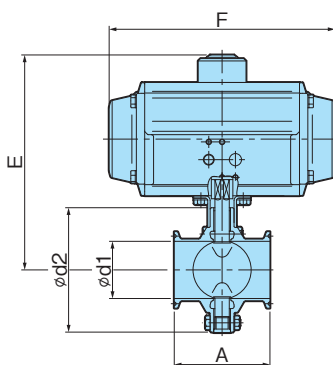

Unit: mm

| Nominal Size (DN) | 25 (1S) | 40 (1.5S) | 50 (2S) | 65 (2.5S) | 80 (3S) | 100 (4S) |
|-------------------|---------|-----------|---------|-----------|---------|----------|
| d1 | 23 | 35.7 | 47.8 | 59.5 | 72.3 | 97.6 |
| d2 | 77 | 91 | 104 | 126 | 126 | 150 |
| A | 80 | 80 | 80 | 100 | 100 | 125 |
| E | 142 | 179 | 184 | 198 | 211 | 223 |
| F | 136 | 204 | 204 | 204 | 241 | 241 |

4-4. Powder & Granule / Tablet Discharge Valves

1 [Powder & Granular Product Discharging] Sanitary Butterfly Valves

Features

- The main parts are made of stainless steel and the wetted parts are #400 buffed finish, which eliminates the adhesion of powder and granules and provides excellent cleanability.
- Light-weight design provides the ease of attaching and detaching on the containers and piping.
- Adoption of clamp type allows the quick assembly/disassembly and easy washing.

Standard Specifications

| | |
|---------------------------------|---|
| Type | DC507C-SI |
| Nominal Size (DN) | 100 (4.5S)–300 (12S) |
| Valve Seat Air-Tightness | 3 kPa |
| Shell Test | 0.05 MPa |
| Working Temperature | Ordinary Temperature (Washable with hot water up to 80 °C) |
| Connection Standard | Ferrule Type DN100 (4.5S), 125 (5.5S), 150 (6.5S), 200: Based on ISO/IDF DN250, 300: for discussion |

- Automatic Valve: Contact us for manufacturing of pneumatically operated ON-OFF valves.
- Applicable only for powder & granular discharging.



2 [Tablet Discharging] Sanitary Dampers

Features

- The main parts are made of #300 buffing finished stainless steel on both inner/outer surfaces that ensures an excellent washability with adhesion-free property for tablets.
- Safe discharging of tablets ensured by optimum shape and structure preventing the tablets from remaining.
- The tablets are fed while the damper is closed and the damper is opened for discharging. The structure is designed in such a way that the tablets are not crushed.
- A stopper at the closing position securely maintains the precise position.

Standard Specifications

| | |
|----------------------------|---------------------------------|
| Type | DC507D |
| Nominal Size (DN) | 150 (6.5S) |
| Connection Standard | Ferrule Type (Based on ISO/IDF) |



Please refer to a catalog "SANITARY TYPE PRODUCTS FOR MEDICAL PLANT" as well for details of products.

4-5. Ultra-High Airtight Dampers

1 Features of Products

Features

- Air tightness of “Zero Leakage”
- Non-Sliding structure of disk and seat prevents wear due to operation and maintains the long-term air tightness.
- All the parts contacting conditioning air are made of stainless steel (SUS304). In addition, metal touch closing action of valve seat reduces deterioration and that will maintain the air tightness for a long period.

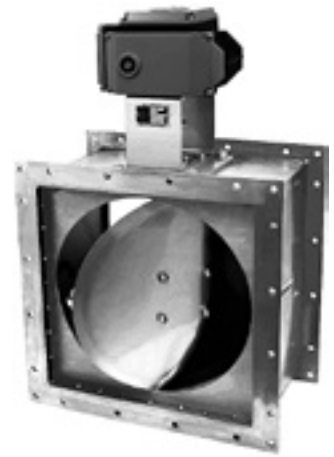

Main Applications

- Bio, general aseptic room, other cleaning workrooms and ducts for air conditioning that may be sterilized.
- When the contamination due to entrance of outdoor air has to be prevented.
- Work rooms or laboratories the air exhausting from the room has to be avoided.
- Experimental clean animal breeding room and the test research laboratory that use it.

2 Product Specifications

Standard Specifications

| | |
|-----------------------------------|--|
| Main Body · Disk Materials | SUS304 (Metal Touch) |
| Size [mm (inch)] | 200 (8B)–650 (26B) |
| Working Temperature Range | 5 to 70 °C |
| Operation Type | Standard: Electrical Operation Option: Lever Handle, Worm Gear, Pneumatic Operation |

Electrically Operated Device Specifications

| Device Type | Damper Size | Open/Close Time 50/60 Hz | Power Supply | Output | Space Heater | Thermal Class | Ambient Temp. |
|----------------|-------------|--------------------------|--------------|--------|--------------|---------------|---------------|
| SRH-007 | 200–450 | 18/15 sec. | AC100V | 10W | 8W | Class-E | –10 to 50 °C |
| | rectangular | 36/30 sec. | | | | | |
| SRH-020 | 500–650 | 18/15 sec. | AC200V | 40W | 8W | Class-E | –10 to 50 °C |
| | rectangular | 36/30 sec. | | | | | |

- Open/close status indication is available using the auxiliary contacts.
- The extended open/close time is available by adding a timer, etc., on the operation panel.

Pressure Loss with regard to Flow Velocity by Port Diameter

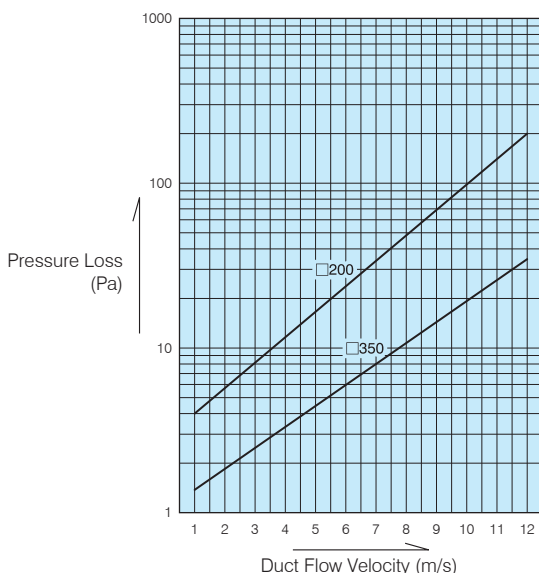

(Pressure Loss when HEPA filter final resistance of 0.4 kPa is applied)

Installation Posture

Posture of damper installation can be either upright, sideways, or upside down, but the electrically operated types are not installed upside down due to structural reason.

Others

The following items will be confirmed when the customer is inquiring or ordering this damper, regardless of a new installation or an implementation to existing equipment:

- 1 Duct Size
- 2 Flow velocity, static pressure, flow rate in duct
- 3 Operation Type
- 4 Static pressure when reverse flow exists in airflow
- 5 Power source specifications used (for electrical operation)

3 Actuator Selection Table

| Damper Size | Spring Type | Actuator Electrical SRH | Static Pressure (kPa) | | | | | | | | |
|------------------------------|-------------|-------------------------|-----------------------|---|-----|-----|-----|-----|--|--|--|
| | | | -0.5 | 0 | 0.5 | 1.0 | 1.5 | 2.0 | | | |
| <input type="checkbox"/> 200 | | 007 | | | | | | | | | |
| <input type="checkbox"/> 250 | A | 007 | | | | | | | | | |
| | B | 007 | | | | | | | | | |
| <input type="checkbox"/> 300 | A | 007 | | | | | | | | | |
| | B | 007 | | | | | | | | | |
| <input type="checkbox"/> 350 | A | 007 | | | | | | | | | |
| | B | 007 | | | | | | | | | |
| <input type="checkbox"/> 400 | A | 007 | | | | | | | | | |
| | B | 007 | | | | | | | | | |
| <input type="checkbox"/> 450 | A | 007 | | | | | | | | | |
| | B | 007 | | | | | | | | | |
| <input type="checkbox"/> 500 | A | 020 | | | | | | | | | |
| | B | 020 | | | | | | | | | |
| <input type="checkbox"/> 550 | A | 020 | | | | | | | | | |
| | B | 020 | | | | | | | | | |
| <input type="checkbox"/> 600 | A | 020 | | | | | | | | | |
| | B | 020 | | | | | | | | | |
| <input type="checkbox"/> 650 | A | 020 | | | | | | | | | |
| | B | 020 | | | | | | | | | |

Please contact us if pneumatically operated types are planned.

4 Major Dimensions

Standard Electrical Operation Type

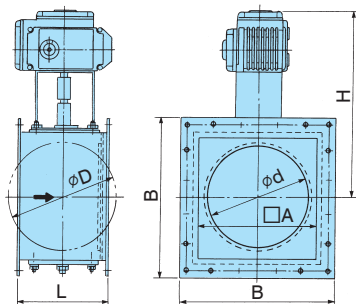

Electrical Operation Twin Type*

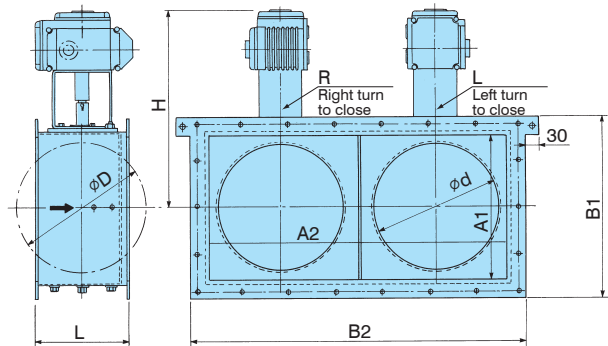

Unit: mm

| Size ** | Ød Port Bore | ØD Disk Dia. | A | B | L | H | Mass (Approx. kg) | Twin | | | |
|---------|--------------|--------------|-----|-----|-----|-----|-------------------|------|------|-----|------|
| | | | | | | | | A1 | A2 | B1 | B2 |
| 200 | 220 | 230 | 255 | 335 | 200 | 413 | 19 | 255 | 535 | 335 | 615 |
| 250 | 270 | 280 | 305 | 385 | | 438 | 21.5 | 305 | 635 | 385 | 715 |
| 300 | 330 | 340 | 355 | 435 | 220 | 463 | 24 | 355 | 735 | 435 | 815 |
| 350 | 380 | 390 | 405 | 485 | 230 | 488 | 26.5 | 405 | 835 | 485 | 915 |
| 400 | 440 | 450 | 445 | 545 | 260 | 563 | 31.5 | 475 | 970 | 545 | 1070 |
| 450 | 480 | 490 | 485 | 585 | 270 | 585 | 34.5 | 515 | 1050 | 585 | 1150 |
| 500 | 538 | 550 | 605 | 713 | 320 | 624 | 98 | 605 | 1210 | 713 | 1318 |
| 550 | 593 | 605 | 660 | 768 | | 651 | 103 | 660 | 1320 | 768 | 1428 |
| 600 | 648 | 660 | 715 | 823 | | 679 | 108 | 715 | 1430 | 823 | 1538 |
| 650 | 704 | 716 | 770 | 878 | | 706 | 118 | 770 | 1540 | 878 | 1648 |

* A large size twin damper consisting of 2 dampers has a double capacity. Triple damper types are manufactured to order.

** The above table shows the approximate dimensions of rectangular flanges. Round flanges are manufactured to order.

Memo

A series of horizontal dotted lines for writing.

5

Technical Materials

- ① Valve Main Body Dimension List
- ② Inspection Pressure
- ③ Cleaning Specifications
- ④ Valve Stroke and Cv-Value
- ⑤ Pneumatically Operated ON-OFF Actuator Selection Table:
Operation Pressure 0.3 MPa
- ⑥ Product Code Descriptions
- ⑦ Air Chamber Volume and Air Consumption for BPO1400NB(N)
- ⑧ Test Certificates

5. Technical Materials

1 Valve Main Body Dimension List

Stainless Steel Main Bodies

Ferrule (Clamp Joint) NDV Connection Standard Code: ISSC

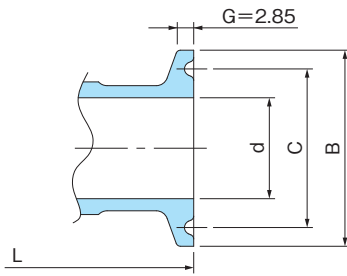

Unit: mm

| Nominal Size | DN | 8 | 10 | 15 | 20 | 25 | 40 | 50 | 65 | 80 | 100 |
|----------------|----|------|------|------|------|------|------|------|------|------|-------|
| | S | — | — | — | — | 1S | 1.5S | 2S | 2.5S | 3S | 4S |
| Face to Face L | | 90 | 90 | 102 | 118 | 127 | 159 | 191 | 216 | 254 | 305 |
| B | | 34.0 | 34.0 | 34.0 | 50.5 | 50.5 | 50.5 | 64.0 | 77.5 | 91.0 | 119.0 |
| C | | 27.5 | 27.5 | 27.5 | 43.5 | 43.5 | 43.5 | 56.5 | 70.5 | 83.5 | 110.0 |
| d | | 10.5 | 14.0 | 17.5 | 23.0 | 23.0 | 35.7 | 47.8 | 59.5 | 72.3 | 97.6 |

- B, C, and G are in accordance with ISO 2852. B=ø50.5, C=ø43.5 are available for DN15 as well.
- d: DN8–20 are in accordance with the bore dimensions of stainless steel pipe for piping (schedule 10S) in JIS G3459. DN25–100 are in accordance with the bore dimensions of stainless steel sanitary pipe for piping in JIS G3447.

Welded Joint/Astro (TIG) Welding NDV Connection Standard Code: JT

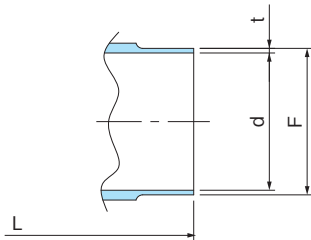

Unit: mm

| Nominal Size | DN | 8 | 10 | 15 | 20 | 25 | 40 | 50 | 65 | 80 | 100 |
|----------------|----|------|------|------|------|------|------|------|------|------|-------|
| | S | — | — | — | — | 1S | 1.5S | 2S | 2.5S | 3S | 4S |
| Face to Face L | | 80 | 80 | 102 | 118 | 127 | 159 | 191 | 216 | 254 | 305 |
| F | | 13.8 | 17.3 | 21.7 | 27.2 | 25.4 | 38.1 | 50.8 | 63.5 | 76.3 | 101.6 |
| t | | 1.65 | 1.65 | 2.1 | 2.1 | 1.2 | 1.2 | 1.5 | 2.0 | 2.0 | 2.0 |
| d | | 10.5 | 14.0 | 17.5 | 23.0 | 23.0 | 35.7 | 47.8 | 59.5 | 72.3 | 97.6 |

Union Screw Joint NDV Connection Standard Code: ISSU

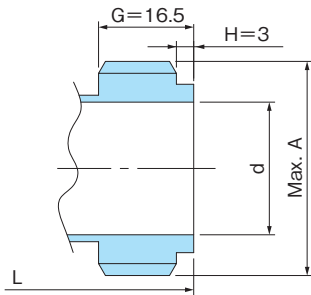

Unit: mm

| Nominal Size | DN | 8 | 10 | 15 | 20 | 25 | 40 | 50 | 65 | 80 | 100 |
|----------------|----|---|----|----|----|-------|-------|-------|-------|-------|--------|
| | S | — | — | — | — | 1S | 1.5S | 2S | 2.5S | 3S | 4S |
| Face to Face L | | — | — | — | — | 127 | 159 | 191 | 216 | 254 | 305 |
| A | | — | — | — | — | 37.13 | 50.65 | 64.16 | 77.67 | 91.19 | 118.21 |
| d | | — | — | — | — | 23.0 | 35.7 | 47.8 | 59.5 | 72.3 | 97.6 |

- A, G and H are in accordance with ISO 2852. (Basic Thread Profile: 29° trapezoidal thread, 8 threads/inch)

Flange Joint (JIS 10KFF) NDV Connection Standard Code: J10KFF

Main Body Material: SUS316L

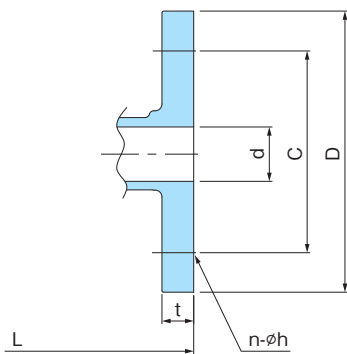

Unit: mm

| Nominal Size DN | 8 | 10 | 15 | 20 | 25 | 40 | 50 | 65 | 80 | 100 |
|-----------------|------|------|------|------|------|------|------|------|------|------|
| Face to Face L | 118 | 118 | 102 | 118 | 127 | 159 | 191 | 216 | 254 | 305 |
| D | 90 | 90 | 95 | 100 | 125 | 140 | 155 | 175 | 185 | 210 |
| C | 65 | 65 | 70 | 75 | 90 | 105 | 120 | 140 | 150 | 175 |
| d | 10.5 | 14.0 | 17.5 | 23.0 | 23.0 | 35.7 | 47.8 | 59.5 | 72.3 | 97.6 |
| h | 15 | 15 | 15 | 15 | 19 | 19 | 19 | 19 | 19 | 19 |
| n | 4 | 4 | 4 | 4 | 4 | 4 | 4 | 4 | 8 | 8 |
| t | 12 | 12 | 12 | 14 | 14 | 16 | 16 | 18 | 18 | 18 |

- Flanges are in accordance with JIS B2220 (Steel pipe flange, Nominal Pressure 10 K).
- The dimensions L, D, C, h and t for DN8 are identical with DN10.

Main Body Material: SCS16

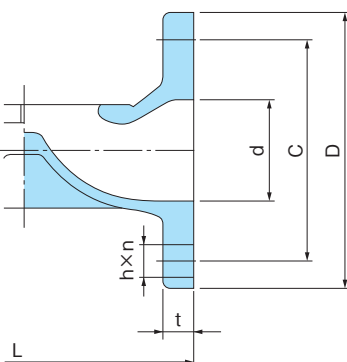

Unit: mm

| Nominal Size DN | 8 | 10 | 15 | 20 | 25 | 40 | 50 | 65 | 80 | 100 |
|-----------------|---|----|-----|-----|-----|-----|-----|-----|-----|-----|
| Face to Face L | — | — | 102 | 118 | 127 | 159 | 191 | 216 | 254 | 305 |
| D | — | — | 95 | 100 | 125 | 140 | 155 | 175 | 185 | 210 |
| C | — | — | 70 | 75 | 90 | 105 | 120 | 140 | 150 | 175 |
| d | — | — | 13 | 19 | 25 | 38 | 51 | 64 | 76 | 102 |
| h | — | — | 15 | 15 | 19 | 19 | 19 | 19 | 19 | 19 |
| n | — | — | 4 | 4 | 4 | 4 | 4 | 4 | 8 | 8 |
| t | — | — | 10 | 10 | 10 | 13 | 14 | 14 | 14 | 17 |

- Flanges are in accordance with JIS B2220 (Steel pipe flange, Nominal pressure 10 K). (Flange thickness t is in accordance with Class D of British Standard)

Lined Main Bodies

PFA Lined Flange Joint (JIS 10KRF) NDV Connection Standard Code: J10KRF

Base Material: SCS13



Unit: mm

| Nominal Size DN | 8 | 10 | 15 | 20 | 25 | 40 | 50 | 65 | 80 | 100 |
|-----------------|---|----|------|------|------|------|------|------|------|-----|
| Face to Face L | — | — | 107 | 123 | 132 | 165 | 197 | 222 | 260 | — |
| T | — | — | 2.5 | 2.5 | 2.5 | 2.5 | 2.5 | 3.0 | 3.0 | — |
| D | — | — | 95 | 100 | 125 | 140 | 155 | 175 | 185 | — |
| C | — | — | 70 | 75 | 90 | 105 | 120 | 140 | 150 | — |
| d | — | — | 13 | 19 | 25 | 38 | 51 | 64 | 76 | — |
| g | — | — | 48 | 52 | 62 | 78 | 89 | 112 | 125 | — |
| h | — | — | 15 | 15 | 19 | 19 | 19 | 19 | 19 | — |
| n | — | — | 4 | 4 | 4 | 4 | 4 | 4 | 8 | — |
| t | — | — | 10.5 | 10.5 | 10.5 | 13.5 | 14.0 | 14.0 | 14.0 | — |

- DN15–65: Material Code 59 (2S), DN80: Material Code 59 (S)
- Flanges are in accordance with JIS B2220 (Steel pipe flange, Nominal pressure 10 K). (Flange thickness t is in accordance with Class D of British Standard. Dimension T for RF is our company standard.)

Base Material: FCD-S

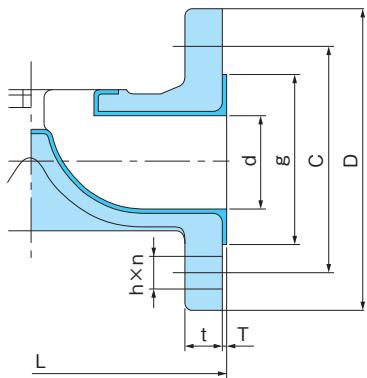

Unit: mm

| Nominal Size DN | 8 | 10 | 15 | 20 | 25 | 40 | 50 | 65 | 80 | 100 |
|-----------------|---|----|------|------|------|------|------|------|------|------|
| Face to Face L | — | — | 107 | 123 | 132 | 165 | 197 | 222 | 260 | 313 |
| T | — | — | 2.5 | 2.5 | 2.5 | 3.0 | 3.0 | 3.0 | 3.0 | 4.0 |
| D | — | — | 95 | 100 | 125 | 140 | 155 | 175 | 185 | 210 |
| C | — | — | 70 | 75 | 90 | 105 | 120 | 140 | 150 | 175 |
| d | — | — | 15 | 20 | 25 | 40 | 50 | 64 | 76 | 102 |
| g | — | — | 48 | 52 | 62 | 78 | 88 | 112 | 125 | 145 |
| h | — | — | 15 | 15 | 19 | 19 | 19 | 19 | 19 | 19 |
| n | — | — | 4 | 4 | 4 | 4 | 4 | 4 | 8 | 8 |
| t | — | — | 13.5 | 13.5 | 13.5 | 16.5 | 19.0 | 19.0 | 19.0 | 22.0 |

- Flanges are in accordance with JIS B2220 (Steel pipe flange, Nominal pressure 10 K). (Flange thickness t is in accordance with Class D of British Standard. Dimension T for RF is our company standard.)

ETFE Lined Ferrule (Clamp Joint) NDV Connection Standard Code: ISSC

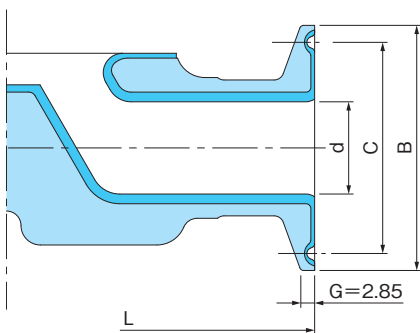

Unit: mm

| Nominal Size | DN 8 | 10 | 15 | 20 | 25 | 40 | 50 | 65 | 80 | 100 |
|----------------|------|----|----|----|------|------|------|------|----|-----|
| Face to Face L | — | — | — | — | 127 | 159 | 191 | 216 | — | — |
| B | — | — | — | — | 50.5 | 50.5 | 64.0 | 77.5 | — | — |
| C | — | — | — | — | 43.5 | 43.5 | 56.5 | 70.5 | — | — |
| d | — | — | — | — | 17.5 | 31.5 | 44.0 | 55.0 | — | — |

- B, C, and G are in accordance with ISO 2852.

2 Inspection Pressure

Inspections are carried out in accordance with our standards below:

| | |
|----------------------------|---|
| Pressure Inspection | Shell Test: Inspected using N2 gas of 'max. working pressure × 1.2'. Seat Leakage Test: Inspected using N2 gas of 0.6 MPa. |
| Inspection Duration | Shell Test: DN50 (2S) and smaller—15 sec., DN65 (2.5S) and larger—60 sec. Seat Leakage Test: DN50 (2S) and smaller—15 sec., DN65 (2.5S) and larger—30 sec. |

- In addition, an air tightness inspection for pneumatically operated actuator is conducted.
- After pressure inspection, the inside of valve main body is washed with pure water.

3 Cleaning Specifications

Parts Processing Before Assembling



Cleaning after Assembly Inspection



4 Valve Stroke and Cv-Value

Main Body: SUS316L, Diaphragm: New PTFE/EPDM

| Nominal Size (DN) | Stroke (mm) | Standard Main Body | Self-Drain |
|-------------------|-------------|--------------------|------------|
| 8 | 4 | 2.9 | 3.1 |
| 10 | 4 | 3.7 | 4.0 |
| 15 | 6 | 5.0 | 4.5 |
| 20 | 8 | 9.0 | 9.0 |
| 25 | 10 | 15.0 | 12.9 |
| 40 | 14 | 36.0 | 32.6 |
| 50 | 20 | 64.0 | 52.6 |
| 65 | 24 | 67.2 | — |
| 80 | 30 | 127.3 | — |
| 100 | 40 | 189.9 | — |

5 Pneumatically Operated ON-OFF Actuator Selection Table: Operating Pressure 0.3 MPa

The actuator for operating pressure 0.3 MPa will be BPO (BPC, BPN) 1400N.

Reverse Acting: BPO1400N

| Nominal Size (DN) | New PTFE Diaphragm | | | | | | | | | |
|-------------------|------------------------|-----|-------|-------|-------|-----|-------|-----|-----|-----|
| | Working Pressure (MPa) | | | | | | | | | |
| | 0.1 | 0.2 | 0.3 | 0.4 | 0.5 | 0.6 | 0.7 | 0.8 | 0.9 | 1.0 |
| 15 | | | | | | | | | | |
| 20 | | | 09B3N | | | | | | | |
| 25 | | | | | 12B3N | | | | | |
| 40 | | | | | | | | | | |
| 50 | | | | | | | | | | |
| 65 | | | | 16B3N | | | | | | |
| 80 | | | 20B3N | | | | 20B3N | | | |
| 100 | | | | 25B3N | | | | | | |

Direct Acting: BPC1400N

| Nominal Size (DN) | New PTFE Diaphragm | | | | | | | | | |
|-------------------|------------------------|-----|------|------|------|-----|------|------|------|-----|
| | Working Pressure (MPa) | | | | | | | | | |
| | 0.1 | 0.2 | 0.3 | 0.4 | 0.5 | 0.6 | 0.7 | 0.8 | 0.9 | 1.0 |
| 15 | | | | | | | | | | |
| 20 | | | 09BN | | | | | | | |
| 25 | | | | | | | 12BN | | | |
| 40 | | | | | | | | | | |
| 50 | | | | 12BN | | | | | 16BN | |
| 65 | | | | | 16BN | | | 20BN | | |
| 80 | | | 20BN | | | | | 25BN | | |
| 100 | | | | | 25BN | | | | | |

Double Acting: BPN1400N

| Nominal Size (DN) | New PTFE Diaphragm | | | | | | | | | |
|-------------------|------------------------|-----|------|-----|-----|------|-----|------|------|-----|
| | Working Pressure (MPa) | | | | | | | | | |
| | 0.1 | 0.2 | 0.3 | 0.4 | 0.5 | 0.6 | 0.7 | 0.8 | 0.9 | 1.0 |
| 15 | | | | | | | | | | |
| 20 | | | 07BN | | | | | | | |
| 25 | | | | | | 09BN | | | | |
| 40 | | | | | | | | | 12BN | |
| 50 | | | | | | | | | | |
| 65 | | | | | | | | 16BN | | |
| 80 | | | 20BN | | | | | | | |
| 100 | | | | | | 25BN | | | | |

Fundamental System of Product Codes: Bioclean Diaphragm Valve

| | | | | | | | | | | | | | | | |
|----------------|------------------|--------------------------|------------|--------------------|---|-------------|-----------|----------|--------------------|----------|--------------|----------|-----------|----------|---------------------|
| B | P0 | M | 1 | 4 | 14 | (E1) | NB | - | TX/CE | - | 050 | - | 16 | - | ISSC |
| ① | ② | ③ | ④ | ⑤ | ⑥ | ⑦ | * | | ⑧ | | ⑨ | | ⑩ | | ⑪ |
| Operation Type | Ancillary Device | Operation Classification | Valve Type | Main Body Material | Base Material for Lining, Surface Finish, Special Main Body | | | | Diaphragm Material | | Nominal Size | | Actuator | | Connection Standard |

① Type B: Bioclean Diaphragm Valves

② Operation Type

| Manually Operated Valve | Blank | Stainless Steel Handle: B400N |
|------------------------------|-------|--|
| | C | Aluminum Handle: BC400 |
| Pneumatically Operated Valve | QL | Quick Open/Close Handle: BQL400NB(N) |
| | PO | ON-OFF Valve Reverse Acting (Air to Open / Spring to Close) |
| | PC | ON-OFF Valve Direct Acting (Air to Close / Spring to Open) |
| | PN | ON-OFF Valve Double Acting (Air to Open / Air to Close) |
| | BO | Rolling Diaphragm Control Valve Reverse Acting (Air to Open / Spring to Close) |
| Electrically Operated Valve | BC | Rolling Diaphragm Control Valve Direct Acting (Air to Close / Spring to Open) |
| | NR# | NR Type Actuator (Nihon Koso Co., Ltd.) |

③ Ancillary Device

| Blank | Standard Actuator |
|-------|---|
| L | Lock Nut |
| S | Position Indicator |
| M | Limit Switch / Special Limit Switch Box |
| T | Opening Limit Device |

④ Operation Classification

| Blank | Manually Operated Valve |
|-------|---|
| 1 | Pneumatically Operated ON-OFF Valve |
| 3 | Pneumatically Operated Flow Control Valve |
| 4 | Electrically Operated Valve |

⑤ Valve Type 4: Weir Type Diaphragm Valve: Type 400

⑥ Main Body Material Refer to page 10

⑦ Base Material for Lining, Surface Finish, Special Main Body
(Codes are combined in accordance with specifications)

| Base Material for Lining | |
|--|---|
| 2S, M, etc. | ⑥ Main body material codes |
| Main Body Surface Finish Classifications | |
| Classification Code | Processes |
| B1 | Inner/outer surfaces: #400 Buffing |
| B2 | Inner surface only: #400 Buffing |
| B3 | Outer surface only: #400 Buffing |
| B4 | Outer surface only: #400 Buffing (burnt color) |
| E1 | Electropolishing after #400 Buffing on Inner/Outer surfaces |
| E2 | Electropolishing after #400 Buffing on inner surface |
| Special Main Body | |
| F | Self-drain |
| P | Sampling Valve |
| Q | Sampling Valve (Lightweight type) |
| K | 3-Way Valve |
| T | Tank Bottom Valve |
| A-V | Branch Valve: Mounting patterns |

(Other than the above will be in accordance with designated materials and types)

⑧ Diaphragm Material Refer to page 11

⑨ Nominal Size (DN)
In accordance with ISO 6708
Indication of sizes in inch system (S) are substituted by metric system (DN or A)

⑩ Actuator
In accordance with selection table

⑪ Connection Standard

| ISSC | Ferrule |
|--------|------------------------|
| JT | Astro TIG Welded Joint |
| ISSU | Union Screw |
| VSSC | Special Clamp |
| J10KFF | JIS 10KFF |
| J10KRF | JIS 10KRF |
| A150RF | CL150RF |

(Other than the above will be in accordance with designated materials and types)

*** ID Codes for improved products**
No need for selecting a code because automatically determined when a valve is selected.

| Blank | First Time |
|-------|--------------------------|
| N | Improvement: First Time |
| NB | Improvement: Second Time |

Examples of Descriptions

Examples of a manually operated valve

| | | | | | | | | | | | | | | | |
|--------------------------|-------------------------|------------------------|-------------------------------|---------------------------|--------------------|---|-----------|----------|--------------------------|----------|-------------------------|----------|---------------------|----------|-------------|
| B | QL | | | 4 | 14 | (E1P) | NB | - | TX/CE | - | 025 | - | | - | ISSC |
| ① | ② | ③ | ④ | ⑤ | ⑥ | ⑦ | * | | ⑧ | | ⑨ | | ⑩ | | ⑪ |
| Bioclean diaphragm valve | Quick open/close handle | Ancillary Device: None | Manually operated valve: None | Weir type diaphragm valve | Main body: SUS316L | Main body surface finish: E1 Sampling valve: P | | | Diaphragm: New PTFE/EPDM | | Nominal Size: DN25 (1S) | | Actuator Code: None | | Ferrule |

Example of a pneumatically operated ON-OFF valve

| | | | | | | | | | | | | | | | |
|--------------------------|--|--|-------------------------------------|---------------------------|-----------------------|---------------------------------|-----------|----------|------------------------------|----------|-------------------------|----------|-------------------|----------|---------------|
| B | P0 | T | 1 | 4 | 59 | (2S) | NB | - | TX/CX | - | 050 | - | 16 | - | J10KRF |
| ① | ② | ③ | ④ | ⑤ | ⑥ | ⑦ | * | | ⑧ | | ⑨ | | ⑩ | | ⑪ |
| Bioclean diaphragm valve | Pneumatically operated ON-OFF valve / Reverse Acting (Air to Open / Spring to Close) | Ancillary Device: Opening Limit Device | Pneumatically operated ON-OFF valve | Weir type diaphragm valve | Main body: PFA lining | Base Material for Lining: SCS13 | | | Diaphragm: New PTFE/EPDM + α | | Nominal Size: DN50 (2S) | | Actuator Code: 16 | | JIS 10KRF |

Above is the coding system for our products. An additional code may be added in accordance with the combination of parts, option, special specifications, etc. Please contact us for any questions regarding the details of product coding.

7 Air Chamber Volumes and Air Consumption of BPO1400NB(N)

| | BPO1400NB | | | | BPO1400N | | | |
|---|-----------|--|---------------------|---------------------|----------|---------------------|--|---------------------|
| | Actuator | BPO (Lower Chamber) BPN (Lower Chamber) | BPC (Upper Chamber) | BPN (Upper Chamber) | Actuator | BPO (Lower Chamber) | BPC (Upper Chamber) BPN (Upper Chamber) | BPN (Lower Chamber) |
| Air Chamber Volume Unit: L | 07 (DN15) | 0.08 | 0.1 | 0.14 | 16BN | 1.0 | 1.1 | 1.4 |
| | 09 (DN20) | 0.17 | 0.21 | 0.27 | 20BN | 2.2 | 2.7 | 3.0 |
| | 09 (DN25) | 0.16 | 0.22 | 0.29 | 25BN | 3.1 | 4.7 | 5.5 |
| | 12 (DN40) | 0.33 | 0.55 | 0.76 | — | — | — | — |
| | 16 (DN50) | 0.85 | 1.19 | 1.62 | — | — | — | — |
| Air Consumption Operating Pressure: 0.4 MPa Unit: NL | 07 (DN15) | 0.4 | 0.5 | 1.1 | 16BN | 5.0 | 5.5 | 7.0 |
| | 09 (DN20) | 0.85 | 1.05 | 2.2 | 20BN | 11.0 | 13.5 | 15.0 |
| | 09 (DN25) | 0.8 | 1.1 | 2.25 | 25BN | 15.5 | 23.5 | 27.5 |
| | 12 (DN40) | 1.65 | 2.75 | 5.45 | — | — | — | — |
| | 16 (DN50) | 4.25 | 5.95 | 12.4 | — | — | — | — |
| Air Consumption Operating Pressure: 0.3 MPa Unit: NL | — | — | — | — | 07BN | 0.4 | 0.4 | 0.8 |
| | — | — | — | — | 09BN | 0.8 | 1.2 | 1.2 |
| | — | — | — | — | 12BN | 2.0 | 2.8 | 2.8 |
| | — | — | — | — | 16BN | 4.0 | 4.4 | 5.6 |
| | — | — | — | — | 20BN | 8.8 | 10.8 | 12.0 |
| — | — | — | — | 25BN | 12.4 | 18.8 | 22.0 | |

• Above table shows air consumption per 1 open/close operation.

8 Test Certificates

New PTFE Diaphragm: 4-TX Series



FDA Compliance Test Certificate



Food Sanitation Act (Japan) Compliance Test Certificate



USP Class VI Test Report

PFA Lined Main Body: Type 459 New PFA



FDA Compliance Test Certificate



Food Sanitation Act (Japan) Compliance Test Certificate

For details of each test certificate, please contact us.

6

Safety Instructions

SAFETY INSTRUCTIONS

1. Cautions for Selecting the Valve

① Products described in this catalog have respective range of application specified according to the official standards and our own standard. Customers are requested to check on your conditions for usage (fluid, pressure, temperature, etc.) before selecting an optimum product.

② Select the material for the main body (lining), diaphragm, bonnet, compressor, base and other depending on the fluid you are to handle. As to the materials for the main body (lining) and diaphragm, please refer to the material selection table in the catalog or contact us.

Please note that certain types and sizes of bonnet, compressor, base, etc. are standard manufactured using aluminum alloy. Optionally these products are also manufactured using steel material (FC200, SCS13, etc). When handling some liquid that erodes aluminum alloy, using steel material is recommended for the sake of safety. Please discuss this matter when placing orders.

2. Cautions at Receiving and During Delivery

① Upon receipt of valves, check that the product and quantity are as ordered. Also check if the package and packing are undamaged.

② Certain items weigh heavy. When unloading or delivering the product, mind the safety by using an appropriate hoisting machines, etc. in conformity to Occupational Safety and Health Act or equivalent law. Never enter directly below a hoisted product package or operate the hoist from under the raised package.

③ If wetted, cardboard boxes may lose packing strength. In such a case, handle them with utmost care.

3. Cautions for Storage

① A dustproof cap is attached to the connecting ends and ports for prevention of dust or dirt in the valve. Furthermore, the whole valve is covered with a dust proof bag for the purpose of sustaining the effects of cleaning treatment.

After having taken out a valve from package, do not remove the dust proof bag and dust proof cap until immediately before installation.

Any foreign substances entered in a valve will be a cause for malfunction if bitten between main body and diaphragm, and further extremely deteriorates the quality of surface finish and cleaning treatment of main body.

② The buffing finish is applied on the surfaces of some of the valve main bodies and bonnets. Please pay attention not to damage valve surface during handling of a valve for conveying, etc.

③ To prevent the valve from rust or rubber and plastic material from degradation, store the valve in the following conditions:

- ① Keep away from the rainwater.
- ② Keep away from direct sunlight.
- ③ Keep it at the ambient temperature of 60°C or lower.
- ④ Keep away from high humidity and dusty atmosphere.

4. Cautions for Installation to the Piping

① Remove a cap covering the connecting ends or flanges of main body, and check for no stain inside or adhesion of foreign substances. Further check for cleanliness and absence of foreign substances in the pipeline for implementing a valve, and carryout gas blowing or liquid flushing as necessary.

Any foreign substances entered in a valve will be a cause for leakage if bitten between main body and diaphragm.

② Provide a space around the valve necessary for overhauling. Such a space should allow to replace the diaphragm with the main

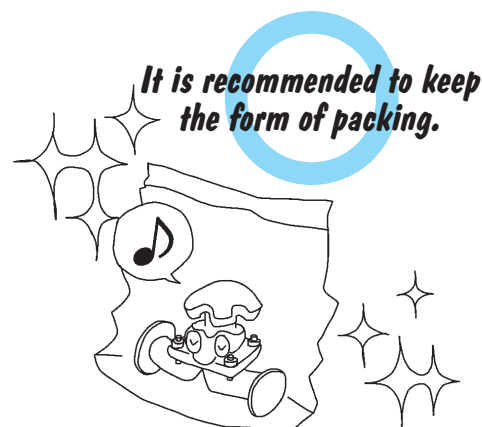

body remaining connected to the piping. Particularly, when hoisting the bonnet, necessary space must be provided for the hoisting operation.

- 3 When installing the valve to the piping, prevent it from receiving abnormal tension, compression or bending stress.
- 4 Use a gasket contacting the full surface of flange for a flat face flange.
- 5 For connection to the piping, use the bolts of a length that makes no contact with the bonnet flange or use continuous thread studs and adjust the length of the protruding head of the stud. Tightening the bolt in contact with the bonnet flange may cause external leakage or damage the bonnet, causing the valve failure.

Particular care is required to the contact of the bonnet flange with the piping bolt when installing a valve of DN15 to 80 to the piping. Users are recommended to use a double-end stud for the piping bolt and the nut of Style 1 (JIS B 1181), Class 1 or 2 (JIS B 1181 Attachment 1).

Make adjustment to prevent contact between the bonnet flange and the piping bolts. Adjustment position should read a position where the end face of the bolt is flush with the end face of the nut. (Select a bolt so that the fit length of the thread will be definitely at least 80% or higher of the height of the nut.)

- 6 When installing the valve to the piping, tighten individual bolts alternately and diagonally under identical torque. Unevenly clamped bolts may cause leakage from the connecting flange face.
- 7 Pay attention not to let the washing water, etc., in the products with air vent (pneumatically operated or electrically operated valves).
- 8 Pay attention not to let the washing water, etc., in actuator if a quantity of washing water, etc., will splash on valves.

- 9 When attaching a valve on a horizontal pipework, install a valve with "TOP" mark upper side (see right figure) and inclined with a certain angle for preventing the fluid from remaining in the valve. Additionally, if a slope is given on the pipework, less fluid will remain and the self-drain effect will be better.

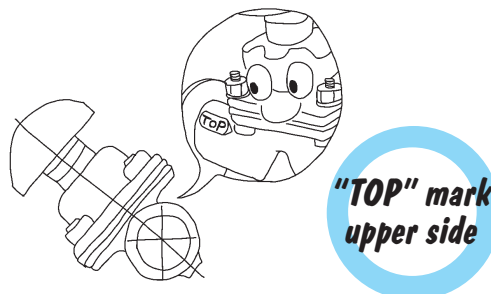

- 10 When a valve with Ferrule joint connection is to be used, add a support for prevention of rotation because the clamp may be loosened due to the rotational force from the weight of actuator and the valve may be rotated.

- 11 For a Ferrule joint, the fastening of clamp shall not be tighter than a strong tightening with a hand. Tightening using a tool, etc., excessive tightening or overload of piping will deform gaskets and will cause leakage or fluid accumulation.

If leakage occurs during use, discharge the pressure in the pipeline and retighten.

If the leakage will not stop, replace the gasket.

5. Cautions for Machine Operation

- 1 Opening/closing the valve with part of an operator's body or wear carelessly in contact with the moving parts inside or outside of the valve may lead to a serious injuries. Never touch the inside or moving parts of the valve.
- 2 When opening/closing the valve, don't operate the handwheel by hooking an auxiliary pipe or wrench on it. Or an excessive load will be applied to the valve component possibly to damage it.
- 3 When operating the handwheel to close the valve, stop the closing operation at maximum 15 to 20 degrees after sensing the valve resistance to the closing motion. Excessive tightening may cause a shorter diaphragm life. Particular care is required when handling a fluid in high temperature.
- 4 If the handwheel operation is felt heavier in the middle of a valve closing operation, certain foreign matters might have been caught with the valve seat. In such a case, open the valve once, let the fluid flow through, and check if the foreign matters are washed away, then start the closing operation again.
- 5 If ambient temperature or fluid temperature changes greatly while the fluid is sealed inside the piping, thermal expansion of the fluid causes the pressure to change, possibly leading to external leakage or damaged diaphragm.

In addition, if the valve is operated to open/close while the valves before and after the diaphragm valve are closed and the inside

fully filled with the fluid, the same phenomenon may occur, for which care should be taken.

- ⑥ If the fluid fully inside the valve is frozen, the valve may be freeze-fractured. For application in an environment where freezing may likely happen, take anti-freeze measures by providing the piping with thermal insulation or if the valve is not in use, to extract liquid from inside the valve, etc.
- ⑦ Make sure that the tightening bolts/nuts of the body and diaphragm are not loose.
If any looseness is found, set the fluid pressure to no load and tighten them uniformly at the specified torque value.
- ⑧ Pay attention on following items when wiring is worked.
 - ① When closing the switch cover, check for the completeness of gasket and clean up the mating surfaces and securely tighten the fastening bolts.
 - ② Securely work not to allow the wash water, etc., to come in from the external lead wire port.
 - ③ Do not leave a switch cover opened.
 - ④ Absolutely avoid wiring work in rainfall when installing outdoors.
 - ⑤ Be sure to check the functioning after wiring work.

6. Cautions for the Actuators of Pneumatically, Electrically Operated Valve

- ① Protective sealing (cap) is provided to the air intake port and the electric wiring connection port. Don't remove the sealing (cap) until the connection joint is installed.
- ② Actuators are shipped factory-adjusted. Don't disassemble and reassemble them. If any adjustment is required, please contact us.
- ③ Dehumidify the air and filter it clean before leading to the valve for application.
- ④ For the operating pressure and power supply, see the nameplate or the specifications of delivered product.
- ⑤ Pay attention not to allow wash water, etc., to come in from the air breathing port of product.

7. Cautions for Disassembly and Assembly

- ① When removing or disassembling the valve, ensure the following matters or you may be risking a serious hazard:
 - ① The object valve should have been separated from other piping.
 - ② The fluid pressure and temperature inside the piping and the valve should be atmospheric and normal.
 - ③ There remains no residual fluid inside the piping, and no fluid leakage occurs when the mounting bolts and nuts are loosened.
- ② Provide maintenance work for the diaphragm and actuator periodically.
 - ① PTFE diaphragm is of a bayonet type. To install to the compressor, push the center of a diaphragm firmly with fingertips. Ensure that the pin has fully entered the compressor before turning it 90 degrees clockwise or counterclockwise. In the case of a reverse seat type diaphragm, turn it over before installation. Turning the diaphragm before the pin fully enters the compressor may damage the pin.
 - ② When reassembling to the valve, run centering, and tighten the bolts and nuts evenly by applying prescribed torque.
 - ③ For detailed maintenance instructions, see the instruction manual or contact our Sales Dept. or local representative.

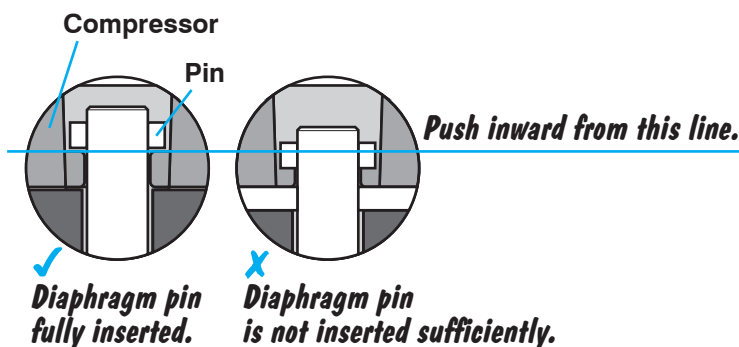

Memo

A series of horizontal dotted lines for writing.

Memo

A series of horizontal dotted lines for writing.

● The ISO 9001 · 14001 certified

 **CAUTION**

Specifications and performance figures of products contained in this catalog are on the design calculations, in-house tests, actual records of product application, and the official standards and specifications. They are presented as the user guide on the use of product concerned under general service conditions. Users intending to use the product under a special condition are required to receive engineering advice from this company in advance or to make their own studies and evaluation to verify performance on their own responsibility. This company shall not be liable for any damages, material or human, that may arise without following this procedure. In as much as full care was taken in editing this catalog, users are kindly requested to make contact with this company for any questions or discrepancies found. This catalog is subject to change without notice for the purpose of correcting error, supplementing or improving insufficient content, updating the content to the improved product performance, design change, discontinuation of product and other reasons. Revised version automatically invalidates catalogs issued prior to the current version. Check the version with our Sales Dept. or local representative before you place orders.

 **WARNING**

 **CAUTION**

There are several points to be noticed for the use of Bioclean Diaphragm Valve based on the structural characteristics. When valve is delivered, a leaflet for Safety Instructions is in the package. Please read this instruction thoroughly before handling and use of products in order to use them safely and stably for a long time.

NDV NIPPON DAIYA VALVE CO., LTD.

Head Office: 1-3-22, Hiro-machi, Shinagawa-ku, Tokyo 140-0005

TOKYO Sales Department: Tel. Tokyo +81-3-3534-5330 Fax. Tokyo +81-3-3490-7950

TIANJIN DAIYA VALVE CO., LTD.: No. 145, 13th Avenue, TEDA, Tianjin 300457 P.R.CHINA

Tel. CHINA +86-22-5981-3960 Fax. CHINA +86-22-5981-3961

NDV (Thailand) Co., Ltd.: 700/691 Moo 1, Tambon Phanthong, Amphur Phanthong, Amata City

Chonburi Industrial Estate, Chonburi 20160, Thailand.

Tel. THAILAND +66-38-109-341 Fax. THAILAND +66-38-109-344

<https://www.ndv.co.jp/english/index.html>

