

SO.No.

JIS 10KRF							
DN	D	C	n	h	t	g	f
15	95	70	4	15	12	51	1
20	100	75	4	15	14	56	1
25	125	90	4	19	14	67	1
40	140	105	4	19	16	81	2
50	155	120	4	19	16	96	2
65	175	140	4	19	18	116	2
80	185	150	8	19	18	126	2
100	210	175	8	19	18	151	2

DN	d	L1	L2	W	H1	H2	E	APPROX. MASS (kg)	Q' TY
15	13	146	73	72	80	-	130	2.9	
20	19	150	75	78	85	-	130	3.6	
25	25	170	85	96	100	-	160	5.6	
40	38	200	100	124	115	-	230	8.8	
50	51	230	115	146	120	-	230	11.7	
65	64	260	130	168	-	135	350	19.0	
80	76	280	140	194	-	145	350	23.0	
100	102	340	170	233	-	180	450	36.0	

流路切換状態図  
Flow Diagrams

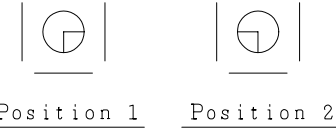

ASME or JPI CLASS 150RF								
NPS	DN	D	C	n	h	t	g	f
1/2	15	89	60.5	4	16	11.5	35.1	1.6
3/4	20	99	69.8	4	16	11.5	42.9	1.6
1	25	108	79.2	4	16	11.5	50.8	1.6
1-1/2	40	127	98.6	4	16	14.5	73.2	1.6
2	50	152	120.6	4	19	16.0	91.9	1.6
2-1/2	65	178	139.7	4	19	18.0	104.6	1.6
3	80	190	152.4	4	19	19.5	127.0	1.6
4	100	229	190.5	8	19	24.0	157.2	1.6

NOTE  
DN50以下のボルト穴(h)は鑄放しとなります。  
配管接続部のRF面は平滑加工になります。  
The finishing for bolt holes (h) of DN50 or smaller is steel casting unmachined.  
The finishes of contact faces of end flanges: Smooth

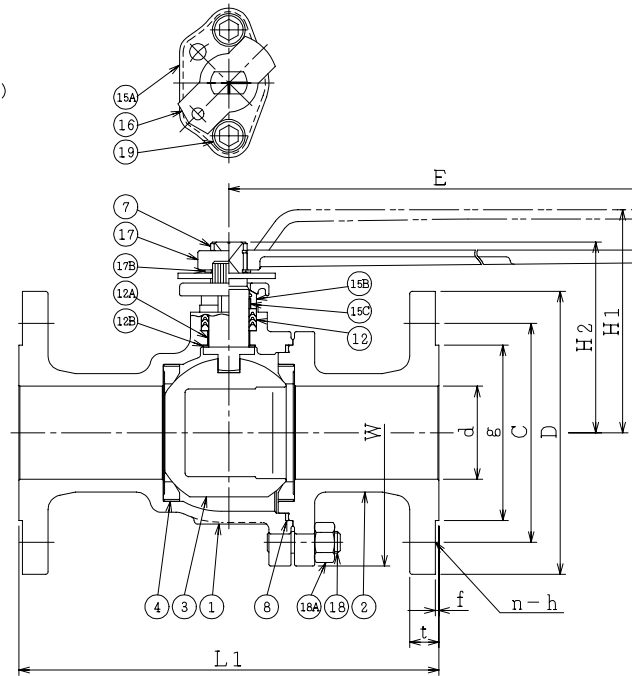
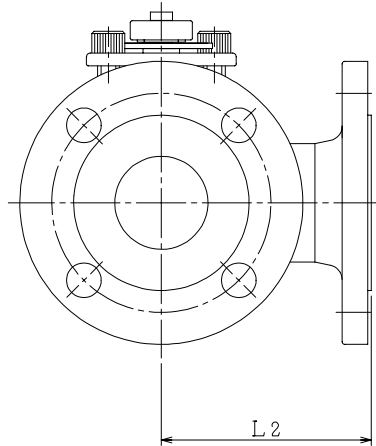

*	シート材料	SEAT MATERIAL
NTF	R.PTFE(NEW PTFE)	
NCF	R.PTFE (カーボンファイバ入り) (CARBON FIBER FILLED)	
NGR	R.PTFE (ガラスファイバ入り) (GLASS FIBER FILLED)	

NOTE  
(\*1) ASTM A351  
(\*2) NEW PTFE

19	六角穴付きボルト	CAP SCREW	SUS304	2	
18A	ナット	NUT	SUS303	4~8	
18	植込みボルト	STUD BOLT	SUS304	4~8	
17B	止め輪	RETAINING RING	SUS304	1	
17	ハンドル	HANDLE	SCPH2	1	
16	ストッパ	TRAVEL STOP	SUS304	1	
15C	ステム軸受	BEARING	NTF	1	(*2)
15B	パッキン押え輪	GLAND	SUS304	1	
15A	パッキン押え	GLAND FLANGE	SCS13A	1	
12B	スラスト座金	THRUST WASHER	NTF	1	(*2)
12A	軸受	BEARING	NTF	1	(*2)
12	パッキン	PACKING	NTF	1S	(*2)
8	ガスケット	GASKET	NTF	1	(*2)
7	ステム	STEM	SUS316	1	
4	シート	SEAT	*	2	
3	ボール	BALL	SUS316 or SCS14A	1	
2	フランジ	CAP	CF8M(*1) SCS14A	1	CL150 J10K
1	本体	BODY	CF8M(*1) SCS14A	1	CL150 J10K

NO.	PART NAME	MATERIAL	Q'TY	REMARKS
ACTION		TITLE 手動操作式3方ボール弁 MANUAL OPERATED 3-WAY BALL VALVE(J10K, CL150)		
APPROVED	K. Shimura	CODE NO.	E312NB-L2- * -15/100	
CHECKED	Y. Kusunoki	DRAWING	NO. FB3045-002A	
DRAWN	S. KITAGAWA	DATE	2013. 4.17	REV. 4

NDV NIPPON DAIYA VALVE CO., LTD.  
TOKYO JAPAN

REV. NO. 4  
DATE 04.11.8  
REV. NO. 3  
DATE 04.10.8  
REV. NO. 2  
DATE 04.1.7  
REV. NO. 1  
DATE 03.1.21  
DRAWN T.MITANI