

SO.No.

JIS 10KRF								
DN	D	C	n	h	t	g	f	
15	95	70	4	15	12	51	1	
20	100	75	4	15	14	56	1	
25	125	90	4	19	14	67	1	
32	135	100	4	19	16	76	2	
40	140	105	4	19	16	81	2	
50	155	120	4	19	16	96	2	
65	175	140	4	19	18	116	2	
80	185	150	8	19	18	126	2	
100	210	175	8	19	18	151	2	

DN	d	L	L1	W	H1	H2	E	APPROX. MASS (kg)	Q'TY
15	13	108	45	72	80	-	130	1.9	
20	19	117	50	78	85	-	130	2.5	
25	25	127	51	96	100	-	160	4.0	
32	38	165	70.5	124	115	-	230	6.5	
40	38	165	70.5	124	115	-	230	6.5	
50	51	178	80.5	146	120	-	230	8.5	
65	64	190	87	168	-	135	350	13.5	
80	76	203	97	194	-	145	350	16.5	
100	102	229	116	233	-	180	450	27.0	

ASME or JPI CLASS 150RF									
NPS	DN	D	C	n	h	t	g	f	
1/2	15	89	60.5	4	16	11.5	35.1	1.6	
3/4	20	99	69.8	4	16	11.5	42.9	1.6	
1	25	108	79.2	4	16	11.5	50.8	1.6	
1-1/4	32	117	88.9	4	16	13.0	63.5	1.6	
1-1/2	40	127	98.6	4	16	14.5	73.2	1.6	
2	50	152	120.6	4	19	16.0	91.9	1.6	
2-1/2	65	178	139.7	4	19	18.0	104.6	1.6	
3	80	190	152.4	4	19	19.5	127.0	1.6	
4	100	229	190.5	8	19	24.0	157.2	1.6	

* シート材料 SEAT MATERIAL	
NTF	R.PTFE (NEW PTFE)
NCF	R.PTFE (カーボンファイバ入り FILLED CARBON FIBER)
NGR	R.PTFE (ガラスファイバ入り FILLED GLASS FIBER)

NOTE
 DN50以下のボルト穴(h)は鑄放しとなります。
 配管接続部のRF面は平滑加工になります。
 The finishing for bolt holes (h) of DN50 or smaller is steel casting unmachined.
 The finishes of contact faces of end flanges:Smooth

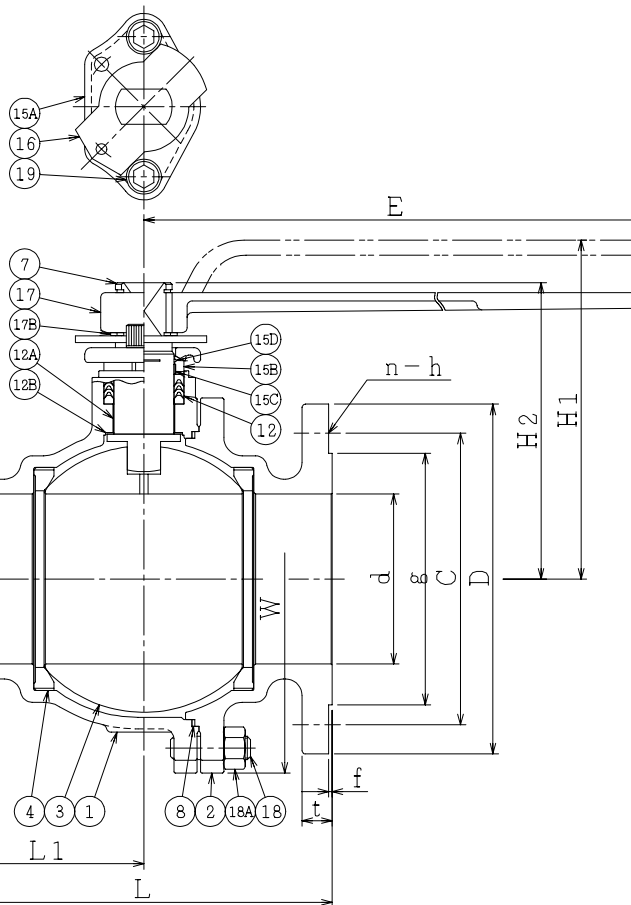

NOTE
 (*1) ASTM A351
 (*2) NEW PTFE

19	六角穴付きボルト	CAP SCREW	SUS304	2	
18A	ナット	NUT	SUS303	4~8	
18	植込みボルト	STUD BOLT	SUS304	4~8	
17B	止め輪	RETAINING RING	SUS304	1	
17	ハンドル	HANDLE	SCPH2	1	
16	ストッパ	TRAVEL STOP	SUS304	1	
15D	ワイヤースプリング	WIRE SPRING	SUS304	1	
15C	ステム軸受	BEARING	NTF	1	(*2)
15B	パッキン押え輪	GLAND	SUS304	1	
15A	パッキン押え	GLAND FLANGE	SCS13A	1	
12B	スラスト座金	THRUST WASHER	NTF	1	(*2)
12A	軸受	BEARING	NTF	1	(*2)
12	パッキン	PACKING	NTF	1S	(*2)
8	ガスケット	GASKET	NTF	1	(*2)
7	ステム	STEM	SUS304	1	
4	シート	SEAT	*	2	
3	ボール	BALL	SUS304 or SCS13A	1	
2	フランジ	CAP	CF8(*1) or SCS13A	1	CL150 J10K
1	本体	BODY	CF8(*1) or SCS13A	1	CL150 J10K

NO.	PART NAME	MATERIAL	Q'TY	REMARKS
ACTION		TITLE		
APPROVED		TITLE		
CHECKED		TITLE		
DRAWN		TITLE		
DATE		TITLE		

NDV NIPPON DAIYA VALVE CO., LTD. TOKYO JAPAN

REV. NO. 2 2 1
 DATE 2013. 7. 23 2013. 7. 13. 3. 7 2012. 9. 27
 DRAWN Y. MIZUSHIMA