

SO.No.

流路切換状態図
Flow Diagrams
数字はポジションを表わします。
(①,②,③,④: Position No.)

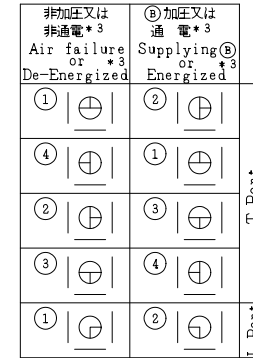

* 3: 電磁弁付の場合
* 3: In case of with Solenoid Valve.

DN	d	L1	L2	W	JIS 10KRF							ACTUATOR CODE PC-	B	m	H	H1	APPROX. MASS (kg)	Q' TY	
					D	C	n	h	t	g	f								
15	19	140	70	80	95	70	4	15	12	51	1	06DN	314	15~18	221	149	8.0		
20	19	140	70	80	100	75	4	15	14	56	1	06DN	314	15~18	221	149	8.5		
25																			
25	25	160	80	90	125	90	4	19	14	67	1	06DN	314	15~18	232	161	11.2		
25																			
40																			
40	38	180	90	138	140	105	4	19	16	81	2	08DN	392	17~21	253	173	15.5		
40																			
50																			
50	51	200	100	160	155	120	4	19	16	96	2	10DN	500	20~26	316	212	26.5		
50																			
65	64	240	120	192	175	140	4	19	18	116	2	12DN	634	26~33	372	254	45.3		
65																			
80	76	260	130	178	185	150	8	19	18	126	2	12DN	634	26~33	412	293	60.5		
80																			

NOTE

DN50以下のボルト穴(h)は鋳放しとなります。
The finishing for bolt holes (h) of DN50 or smaller is steel casting unmachined.

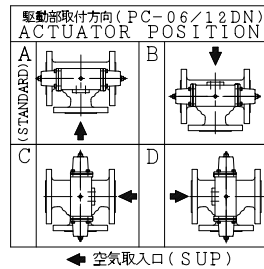

* シート材料	SEAT MATERIAL
NTF	R.PTFE (NEW PTFE)
NCF	R.PTFE (カーボンファイバ入り FILLER) (CARBON FIBER FILLED)
NGR	R.PTFE (ガラスファイバ入り FILLER) (GLASS FIBER FILLED)

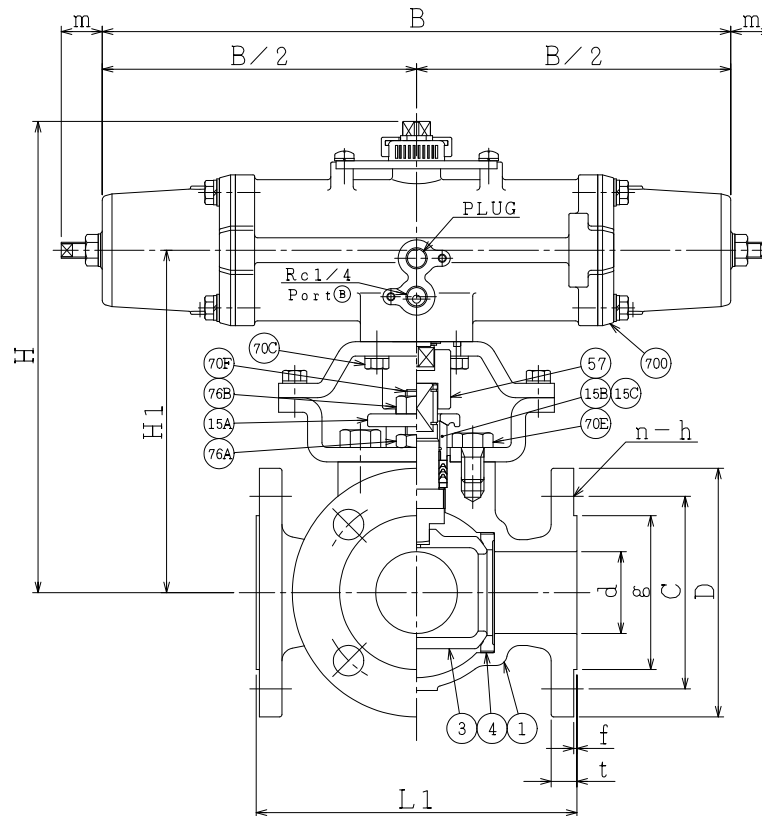
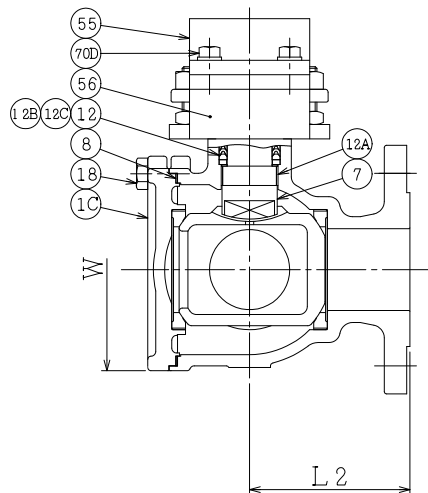

NOTE

(*1) NEW PTFE

700	駆動部	ACTUATOR		1S
76B	六角ナット	NUT	SUS304	2
76A	六角ナット	NUT	SUS304	2
70F	長ねじボルト	STUD BOLT	SUS304	2
70E	六角ボルト	BOLT	SUS304	2
70D	六角ボルト	BOLT	SUS304	4
70C	六角ボルト	BOLT	SUS304	4
57	カップリング	COUPLING	SUS	1
56	ヨーク B	YOKE B	SS400	1
55	ヨーク A	YOKE A	SS400	1
18	六角ボルト	BOLT	SUS304	4~6
15C	ステム軸受	BEARING	NTF	1 (*1)
15B	パッキン押え輪	GLAND	SUS304	1
15A	パッキン押え	GLAND FLANGE	SCS13A	1
12C	座金	WASHER	SUS316	1
12B	スラスト座金	THRUST WASHER	NTF	1 (*1)
12A	軸受	BEARING	NTF	1 (*1)
12	パッキン	PACKING	NTF	1S (*1)
8	ガスケット	GASKET	NTF	1 (*1)
7	ステム	STEM	SUS316	1
4	シート	SEAT	*	4
3	ボール	BALL	SCS14A	1
1C	シート押え	SIDE COVER	SCS14A	1
1	本体	BODY	SCS14A	1

NO.	PART NAME	MATERIAL	Q'TY	REMARKS
ACTION		TITLE		
APPROVED		TITLE		
CHECKED		TITLE		
DRAWN		TITLE		
DATE		TITLE		

NDV NIPPON DAIYA VALVE CO., LTD. TOKYO JAPAN

REV. NO. DATE 2016. 3. 8
REV. 0 DATE 2013. 3. 11 DRAWN S. KITAGAWA