

SO.No.

DN	d	L	L1	k	J	Rp	JIS 20KRF							ACTUATOR CODE PC-	B	m	H	H1	FLANGE DN	APPROX. MASS (kg)	Q' TY
							D	C	n	h	t	g	f								
15														04DN	212	10~13	223	166			7.4
15	13	108	54										05DN	268	13~16	236	172	40		8.3	
20													05DN	268	13~16	240	176			8.7	
20	19	117	58.5										06DN	314	15~18	256	184			10.2	
25													06DN	314	15~18	267	195	50		11.7	
25	25	127	63.5										08DN	392	17~21	308	227	65		21.0	
40	38	165	82.5										08DN	392	17~21	316	235			25.3	
50													10DN	500	20~26	364	260	80		34.0	
50	51	178	93										10DN	500	20~26	400	296			44.5	
65													12DN	634	26~33	431	313	100		56.5	
65	64	190	100										10DN	500	20~26	410	306			55.0	
80													12DN	634	26~33	441	323	125		67.0	
80	76	203	108										12DN	634	26~33	454	336	150		85.6	

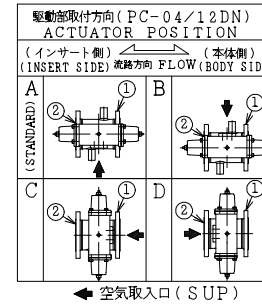

NOTE
 (*1) 強化PTFE (Reinforced PTFE)
 (*2) DN25以下のソケットはバルブ中心に取付けます。
 For DN25 and smaller,
 sockets are placed with
 welding on the plan X-X'.

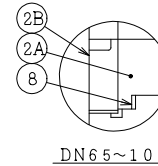
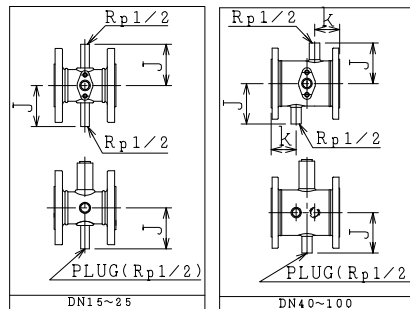
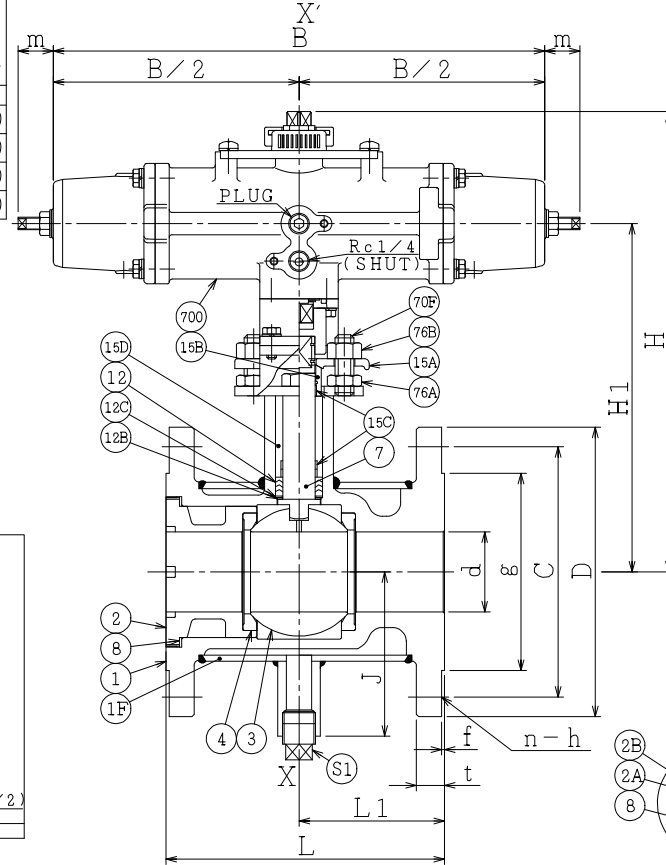
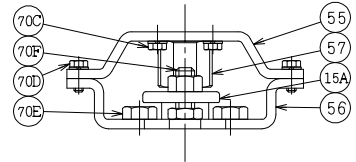
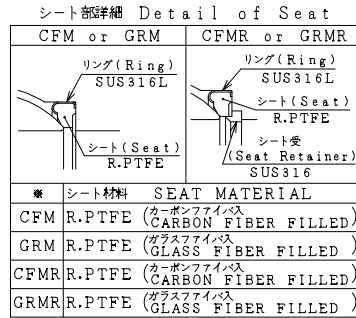

700	駆動部	ACTUATOR	1S	
S1	プラグ	PLUG	SUS304	1
76B	六角ナット	NUT	SUS304	2
76A	六角ナット	NUT	SUS304	2
70F	長ねじボルト	STUD BOLT	SUS304	2
70E	六角ボルト	BOLT	SUS304	2
70D	六角ボルト	BOLT	SUS304	4
70C	六角ボルト	BOLT	SUS304	4
57	カップリング	COUPLING	SUS	1
56	ヨーク B	YOKE B	SS400	1
55	ヨーク A	YOKE A	SS400	1
15D	スペーサ	SPACER	SUS304	1
15C	ステム軸受	BEARING	R.PTFE(*1)	3 FL3000
15B	パッキン押え輪	GLAND	SUS304	1
15A	パッキン押え	GLAND FLANGE	SCS13A	1
12C	座金	WASHER	SUS316	1
12B	スラスト座金	THRUST WASHER	NTF	1 NEW PTFE
12	パッキン	PACKING	R.PTFE(*1)	1S
8	ガスケット	GASKET	PTFE	1
7	ステム	STEM	SUS316	1
4	シート	SEAT	*	2
3	ボール	BALL	SUS316 or SCS14A	1
2B	インサート押え	INSERT RING	SCS14A	1 DN65~100
2A	インサート	INSERT	SCS14A	1 DN65~100
2	インサート	INSERT	SCS14A	1 DN15~50
1F	ジャケットカバー	JACKET	SUS304 or SUS304TP or SCS13A	1
1	本体	BODY	SCS14A	1

NO.	PART NAME	MATERIAL	Q' TY	REMARKS
ACTION 空気消失時 開		TITLE 空気操作式ボール弁		
AIR FAILURE OPEN		PNEUMATIC OPERATED BALL VALVE (J20K)		
APPROVED	Y. Miyazaki	CODE NO.	EPC1112JNC-* -15/100	
CHECKED	Y. Ito	DRAWING NO.	FB2726-004A	
DRAWN	Y. NONAMI	REV.	2	
DATE	2024. 7.31			

NDV NIPPON DAIYA VALVE CO., LTD.
 TOKYO JAPAN

REV. NO. 2 2018.12.17 2024. 7.31
 DATE 2013. 3.13 DRAWN S. KITAGAWA