

SO.No.

DN	d	L	L1	W	JIS 10KRF							ACTUATOR CODE PO-	B	m	H	H1	APPROX. MASS (kg)	Q _v TY
					D	C	n	h	t	g	f							
15	13	108	45	72	95	70	4	15	12	51	1	04DN	212	10~13	175	118	3.5	
15												05DN	268	13~16	188	124	4.4	
20	19	117	50	78	100	75	4	15	14	56	1	05DN	268	13~16	192	128	5.2	
20												06DN	314	15~18	208	136	6.7	
25	25	127	51	96	125	90	4	19	14	67	1	06DN	314	15~18	222	150	8.4	
32	38	165	70.5	124	135	100	4	19	16	76	2	08DN	392	17~21	261	180	15.6	
40	38	165	70.5	124	140	105	4	19	16	81	2	08DN	392	17~21	261	180	15.6	
50	51	178	80.5	146	155	120	4	19	16	96	2	08DN	392	17~21	269	188	17.3	
50												10DN	500	20~26	317	213	26.0	
65	64	190	87	168	175	140	4	19	18	116	2	10DN	500	20~26	345	241	33.0	
65												12DN	634	26~33	376	258	45.0	
80	76	203	97	194	185	150	8	19	18	126	2	10DN	500	20~26	355	251	36.1	
80												12DN	634	26~33	386	268	48.1	
100	102	229	116	233	210	175	8	19	18	151	2	12DN	634	26~33	420	302	60.0	

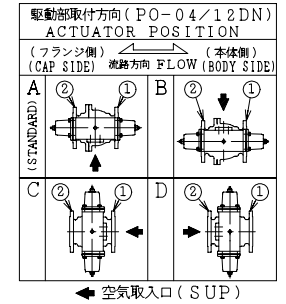

NOTE
(*1) NEW PTFE

700	駆動部	ACTUATOR		1S	
76B	六角ナット	NUT	SUS304	2	
76A	六角ナット	NUT	SUS304	2	
70F	長ねじボルト	STUD BOLT	SUS304	2	
70E	六角ボルト	BOLT	SUS304	2	
70D	六角ボルト	BOLT	SUS304	4	
70C	六角ボルト	BOLT	SUS304	4	
57	カップリング	COUPLING	SUS	1	
56	ヨーク B	YOKE B	SS400	1	
55	ヨーク A	YOKE A	SS400	1	
18A	ナット	NUT	S45C	4~8	
18	植込みボルト	STUD BOLT	SNB7	4~8	
15D	ワイヤースプリング	WIRE SPRING	SUS304	1	
15C	ステム軸受	BEARING	NTF	1	(*1)
15B	パッキン押え輪	GLAND	SUS304	1	
15A	パッキン押え	GLAND FLANGE	SCS13A	1	
12B	スラスト座金	THRUST WASHER	NTF	1	(*1)
12A	軸受	BEARING	NTF	1	(*1)
12	パッキン	PACKING	NTF	1S	(*1)
8	ガスケット	GASKET	NTF	1	(*1)
7	ステム	STEM	SUS304	1	
4	シート	SEAT	*	2	
3	ボール	BALL	SUS304 or SCS13A	1	
2	フランジ	CAP	FCD400	1	
1	本体	BODY	FCD400	1	
NO.	PART NAME		MATERIAL	QTY	REMARKS
ACTION		TITLE			
空気消失時 閉		空気操作式ボール弁			
AIR FAILURE CLOSE		PNEUMATIC OPERATED			
		BALL VALVE (J10K)			
APPROVED	<i>K. Shimura</i>	CODE NO.	FPO1104NB-※-15/100		
CHECKED	<i>Y. Kusumoto</i>	DRAWING	FB2707-005A		
DRAWN	S.KITAGAWA	NO.	0		
DATE	2012.11.13				

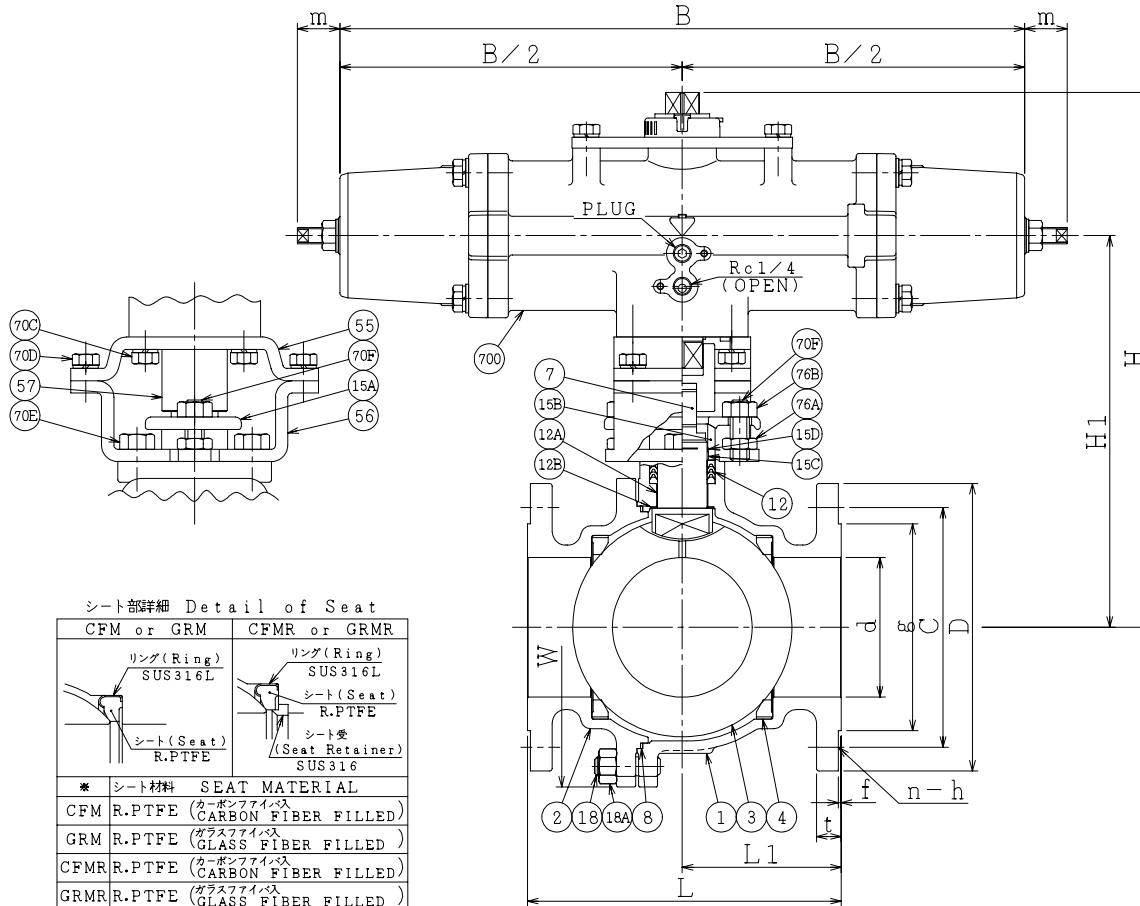

REV NO. DATE
REV 0
DRAWN S.KITAGAWA
DATE 2012.11.13

NDV NIPPON DAIYA VALVE CO., LTD.
TOKYO JAPAN