

SO.No.

NPS	DN	d	L	L1	W	ASME or JPI CLASS 150RF						ACTUATOR CODE PN-	B	m	H	H1	APPROX. MASS (kg)	Q' TY	
						D	C	n	h	t	g								f
1/2	15	13	108	45	72	89	60.5	4	16	11.5	35.1	1.6	04DN	144	0~3	175	118	3.0	
3/4	20	19	117	50	78	99	69.8	4	16	11.5	42.9	1.6	04DN	144	0~3	179	122	3.6	
3/4	20	19	117	50	78	99	69.8	4	16	11.5	42.9	1.6	05DN	172	0~3	192	128	4.0	
1	25	25	127	51	96	108	79.2	4	16	11.5	50.8	1.6	04DN	144	0~3	193	136	5.0	
1	25	25	127	51	96	108	79.2	4	16	11.5	50.8	1.6	05DN	172	0~3	206	142	5.5	
1-1/4	32	38	165	70.5	124	117	88.9	4	16	13.0	63.5	1.6	05DN	172	0~3	224	160	8.9	
1-1/4	32	38	165	70.5	124	117	88.9	4	16	13.0	63.5	1.6	06DN	214	0~3	240	168	9.9	
1-1/2	40	38	165	70.5	124	127	98.6	4	16	14.5	73.2	1.6	05DN	172	0~3	224	160	8.9	
1-1/2	40	38	165	70.5	124	127	98.6	4	16	14.5	73.2	1.6	06DN	214	0~3	240	168	9.9	
2	50	51	178	80.5	146	152	120.6	4	19	16.0	91.9	1.6	06DN	214	0~3	248	176	11.8	
2	50	51	178	80.5	146	152	120.6	4	19	16.0	91.9	1.6	08DN	266	0~4	269	188	15.8	
2-1/2	65	64	190	87	168	178	139.7	4	19	18.0	104.6	1.6	06DN	214	0~3	276	204	17.3	
2-1/2	65	64	190	87	168	178	139.7	4	19	18.0	104.6	1.6	08DN	266	0~4	297	216	19.8	
3	80	76	203	97	194	190	152.4	4	19	19.5	127.0	1.6	08DN	266	0~4	307	226	22.9	
3	80	76	203	97	194	190	152.4	4	19	19.5	127.0	1.6	10DN	336	0~6	355	251	28.6	
4	100	102	229	116	233	229	190.5	8	19	24.0	157.2	1.6	10DN	336	0~6	390	286	39.0	
4	100	102	229	116	233	229	190.5	8	19	24.0	157.2	1.6	12DN	420	2~9	420	302	49.0	
5	125	127	356	148	281	254	215.9	8	22	24.0	185.6	1.6	12DN	420	2~9	459	341	69.5	
6	150	152	394	173	321	279	241.3	8	22	25.5	215.9	1.6	12DN	420	2~9	479	361	84.5	

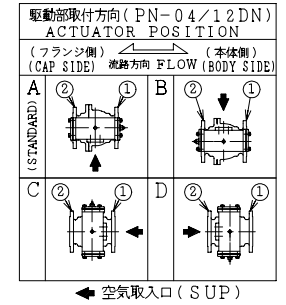

NOTE
 (*1) ASTM A351
 (*2) NEW PTFE

NOTE
 DN50以下のボルト穴(h)は鑄放しとなります。
 配管接続部のRF面は平滑加工になります。
 The finishing for bolt holes (h) of DN50 or smaller is steel casting unmachined.
 The finishes of contact faces of end flanges:Smooth

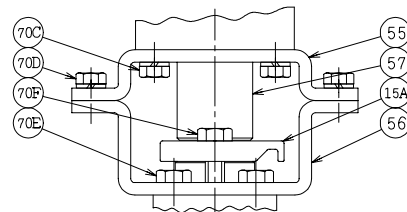

DN125, 150

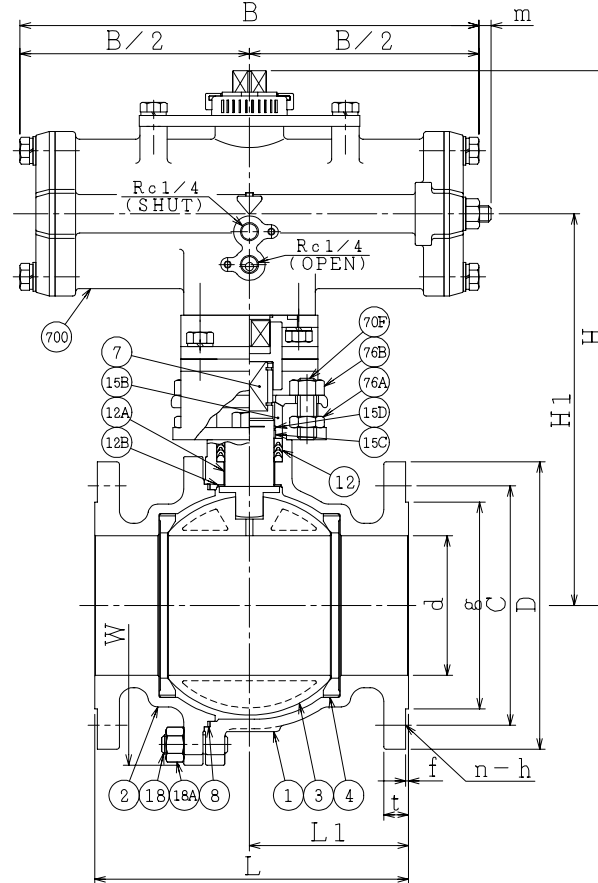

REMARK: 部番3は、DN125, 150のみ、破線の形状となります。
 The shape of DN125, 150 ball is as shown by imaginary line.

700	駆動部	ACTUATOR		1S
76B	六角ナット	NUT	SUS304	2 DN15~100
76A	六角ナット	NUT	SUS304	2 DN15~100
70F	六角ボルト	BOLT	SUS304	2 DN125, 150
70E	長ねじボルト	STUD BOLT	SUS304	2 DN15~100
70D	六角ボルト	BOLT	SUS304	2 DN125, 150:4
70C	六角ボルト	BOLT	SUS304	4
57	カップリング	COUPLING	SUS	1
56	ヨーク B	YOKE B	SS400	1
55	ヨーク A	YOKE A	SS400	1
18A	ナット	NUT	SUS303	4~8
18	植込みボルト	STUD BOLT	SUS304	4~8
15D	ワイヤースプリング	WIRE SPRING	SUS304	1
15C	ステム軸受	BEARING	NTF	1 (*2)
15B	パッキン押え輪	GLAND	SUS304	1
15A	パッキン押え	GLAND FLANGE	SCS13A	1
12B	スラスト座金	THRUST WASHER	NTF	1 (*2)
12A	軸受	BEARING	NTF	1 (*2)
12	パッキン	PACKING	NTF	1S (*2)
8	ガスケット	GASKET	NTF	1 (*2)
7	ステム	STEM	SUS304	1
4	シート	SEAT	*	2
3	ボール	BALL	SUS304 or SCS13A	1
2	フランジ	CAP	CF8	1 (*1)
1	本体	BODY	CF8	1 (*1)
NO.	PART NAME	MATERIAL	Q'TY	REMARKS

ACTION 加圧開, 加圧閉		TITLE 空気操作式ボール弁		
DOUBLE ACTING		PNEUMATIC OPERATED BALL VALVE (CL150)		
APPROVED	K. Shimura	CODE NO.	FPN1107NB- * -15/150	
CHECKED	Y. Kusumoto	DRAWING		REV.
DRAWN	S.KITAGAWA	NO.	FB2706-044A	0
DATE	2012.11. 9			

NDV NIPPON DAIYA VALVE CO., LTD.
 TOKYO JAPAN

REV. NO. DATE
 REV. 0
 2012.11. 9
 DRAWN S.KITAGAWA