

SO.No.

DN	d	L	L1	W	JIS 20KRF							ACTUATOR CODE PN-	B	m	H	H1	APPROX. MASS (kg)	Q/TY
					D	C	n	h	t	g	f							
15	13	140	63	78	95	70	4	15	14	51	1	04DN	144	0~3	175	118	3.4	
20	19	152	70	84	100	75	4	15	16	56	1	04DN	144	0~3	179	122	4.1	
20	19	152	70	84	100	75	4	15	16	56	1	05DN	172	0~3	192	128	4.5	
25	25	165	71	103	125	90	4	19	16	67	1	04DN	144	0~3	193	136	5.7	
25	25	165	71	103	125	90	4	19	16	67	1	05DN	172	0~3	206	142	6.2	
32	38	190	76.5	130	135	100	4	19	18	76	2	05DN	172	0~3	224	160	9.7	
32	38	190	76.5	130	135	100	4	19	18	76	2	06DN	214	0~3	240	168	10.7	
40	38	190	76.5	130	140	105	4	19	18	81	2	05DN	172	0~3	224	160	9.7	
40	38	190	76.5	130	140	105	4	19	18	81	2	06DN	214	0~3	240	168	10.7	
50	51	216	86	156	155	120	8	19	18	96	2	06DN	214	0~3	248	176	13.4	
50	51	216	86	156	155	120	8	19	18	96	2	08DN	266	0~4	269	188	17.4	
65	64	241	103	184	175	140	8	19	20	116	2	06DN	214	0~3	276	204	20.8	
65	64	241	103	184	175	140	8	19	20	116	2	08DN	266	0~4	297	216	23.3	
80	76	283	124	204	200	160	8	23	22	132	2	08DN	266	0~4	307	226	29.4	
80	76	283	124	204	200	160	8	23	22	132	2	10DN	336	0~6	355	251	35.1	
100	102	305	135	252	225	185	8	23	24	160	2	10DN	336	0~6	390	286	50.5	
100	102	305	135	252	225	185	8	23	24	160	2	12DN	420	2~9	420	302	60.5	
125	127	381	158	296	270	225	8	25	26	195	2	12DN	420	2~9	459	341	82.5	
150	152	403	178	321	305	260	12	25	28	230	2	12DN	420	2~9	479	361	98.5	

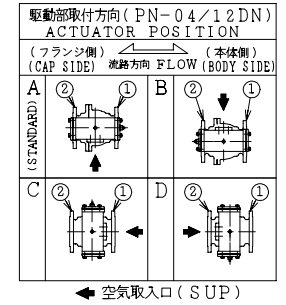

NOTE
(*1) NEW PTFE

NOTE
DN50以下のボルト穴(h)は鑄放しとなります。
The finishing for bolt holes (h) of DN50 or smaller is steel casting unmachined.

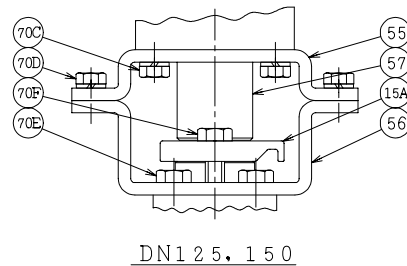

DN125, 150

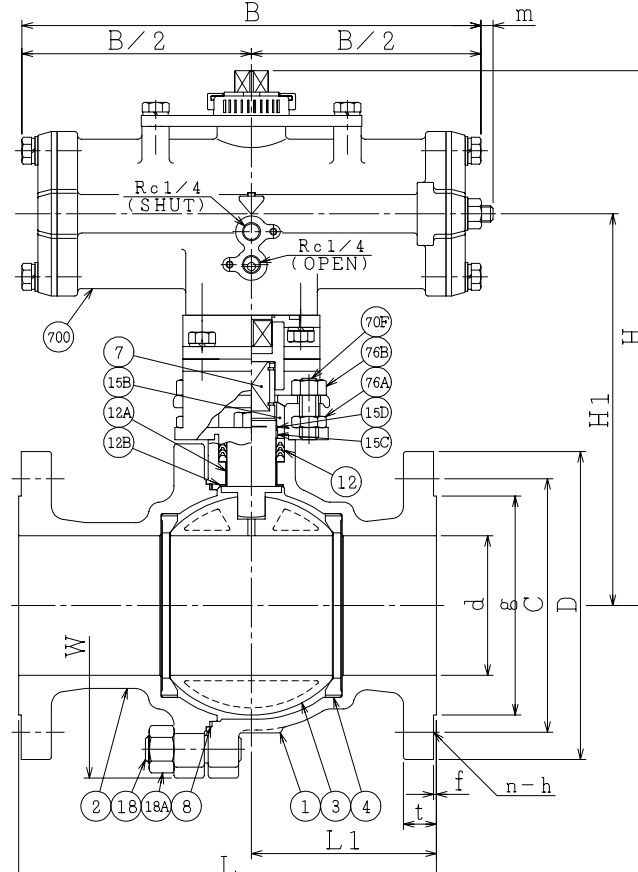

REMARK: 部番3は、DN125, 150のみ、破線の形状となります。
The shape of DN125, 150 ball is as shown by imaginary line.

700	駆動部	ACTUATOR		1S
76B	六角ナット	NUT	SUS304	2 DN15~100
76A	六角ナット	NUT	SUS304	2 DN15~100
70F	六角ボルト	BOLT	SUS304	2 DN125, 150
	長ねじボルト	STUD BOLT	SUS304	2 DN15~100
70E	六角ボルト	BOLT	SUS304	2 DN125, 150:4
70D	六角ボルト	BOLT	SUS304	4
70C	六角ボルト	BOLT	SUS304	4
57	カップリング	COUPLING	SUS	1
56	ヨーク B	YOKE B	SS400	1
55	ヨーク A	YOKE A	SS400	1
18A	ナット	NUT	SUS303	4~12
18	植込みボルト	STUD BOLT	SUS304	4~12
15D	ワイヤースプリング	WIRE SPRING	SUS304	1
15C	ステム軸受	BEARING	NTF	1 (*1)
15B	パッキン押え輪	GLAND	SUS304	1
15A	パッキン押え	GLAND FLANGE	SCS13A	1
12B	スラスト座金	THRUST WASHER	NTF	1 (*1)
12A	軸受	BEARING	NTF	1 (*1)
12	パッキン	PACKING	NTF	1S (*1)
8	ガスケット	GASKET	NTF	1 (*1)
7	ステム	STEM	SUS304	1
4	シート	SEAT	*	2
3	ボール	BALL	SUS304 or SCS13A	1
2	フランジ	CAP	SCS13A	1
1	本体	BODY	SCS13A	1

NO.	PART NAME	MATERIAL	Q'TY	REMARKS
ACTION 加圧開, 加圧閉		TITLE 空気操作式ボール弁		
DOUBLE ACTING		PNEUMATIC OPERATED BALL VALVE (J20K)		
APPROVED	K. Shimura	CODE NO.	FPN1107NB- * -15/150	
CHECKED	Y. Kusumoto	DRAWING	FB2706-025A	
DRAWN	S.KITAGAWA	NO.	0	
DATE	2012.11. 9			

NDV NIPPON DAIYA VALVE CO., LTD.
TOKYO JAPAN

REV. 0
DATE 2012.11. 9
DRAWN S.KITAGAWA