

SO.No.

DN	d	L	L1	W	JIS 10KRF								ACTUATOR CODE PN-	B	m	H	H1	APPROX. MASS (kg)	Q' TY
					D	C	n	h	t	g	f								
15	13	108	45	72	95	70	4	15	12	51	1	04DN	144	0~3	175	118	3.0		
20	19	117	50	78	100	75	4	15	14	56	1	04DN	144	0~3	179	122	3.6		
20	19	117	50	78	100	75	4	15	14	56	1	05DN	172	0~3	192	128	4.0		
25	25	127	51	96	125	90	4	19	14	67	1	04DN	144	0~3	193	136	5.0		
25	25	127	51	96	125	90	4	19	14	67	1	05DN	172	0~3	206	142	5.5		
32	38	165	70.5	124	135	100	4	19	16	76	2	05DN	172	0~3	224	160	8.9		
32	38	165	70.5	124	135	100	4	19	16	76	2	06DN	214	0~3	240	168	9.9		
40	38	165	70.5	124	140	105	4	19	16	81	2	05DN	172	0~3	224	160	8.9		
40	38	165	70.5	124	140	105	4	19	16	81	2	06DN	214	0~3	240	168	9.9		
50	51	178	80.5	146	155	120	4	19	16	96	2	06DN	214	0~3	248	176	11.8		
50	51	178	80.5	146	155	120	4	19	16	96	2	08DN	266	0~4	269	188	15.8		
65	64	190	87	168	175	140	4	19	18	116	2	06DN	214	0~3	276	204	17.3		
65	64	190	87	168	175	140	4	19	18	116	2	08DN	266	0~4	297	216	19.8		
80	76	203	97	194	185	150	8	19	18	126	2	08DN	266	0~4	307	226	22.9		
80	76	203	97	194	185	150	8	19	18	126	2	10DN	336	0~6	355	251	28.6		
100	102	229	116	233	210	175	8	19	18	151	2	10DN	336	0~6	390	286	39.0		
100	102	229	116	233	210	175	8	19	18	151	2	12DN	420	2~9	420	302	49.0		
125	127	356	148	281	250	210	8	23	20	182	2	12DN	420	2~9	459	341	69.5		
150	152	394	173	321	280	240	8	23	22	212	2	12DN	420	2~9	479	361	84.5		

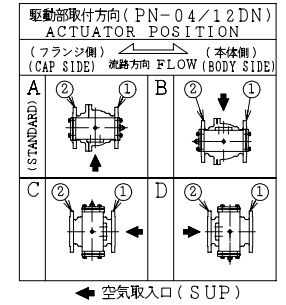

NOTE
(*1) NEW PTFE

NOTE
DN50以下のボルト穴(h)は鑄放しとなります。
The finishing for bolt holes (h) of DN50 or smaller is steel casting unmachined.

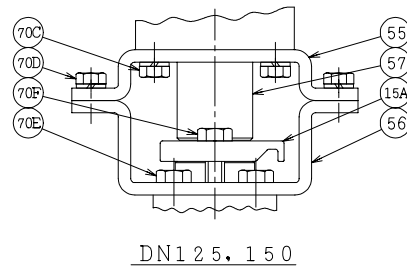

DN125, 150

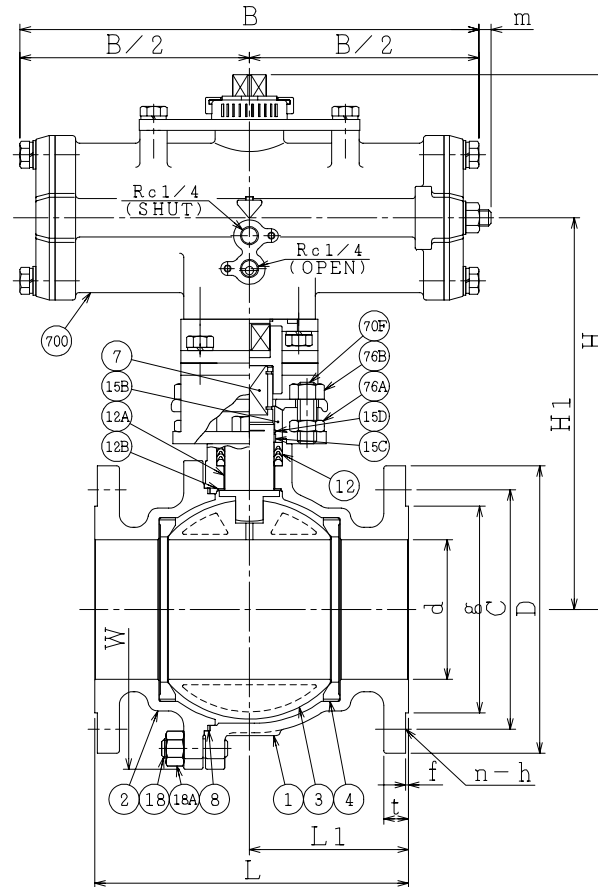

REMARK: 部番3は、DN125, 150のみ、破線の形状となります。
The shape of DN125, 150 ball is as shown by imaginary line.

700	駆動部	ACTUATOR	1S	
76B	六角ナット	NUT	SUS304	2 DN15~100
76A	六角ナット	NUT	SUS304	2 DN15~100
70F	六角ボルト	BOLT	SUS304	2 DN125, 150
70E	六角ボルト	BOLT	SUS304	2 DN15~100
70D	六角ボルト	BOLT	SUS304	4 DN125, 150:4
70C	六角ボルト	BOLT	SUS304	4
57	カップリング	COUPLING	SUS	1
56	ヨーク B	YOKE B	SS400	1
55	ヨーク A	YOKE A	SS400	1
18A	ナット	NUT	SUS303	4~8
18	植込みボルト	STUD BOLT	SUS304	4~8
15D	ワイヤースプリング	WIRE SPRING	SUS304	1
15C	ステム軸受	BEARING	NTF	1 (*1)
15B	パッキン押え輪	GLAND	SUS304	1
15A	パッキン押え	GLAND FLANGE	SCS13A	1
12B	スラスト座金	THRUST WASHER	NTF	1 (*1)
12A	軸受	BEARING	NTF	1 (*1)
12	パッキン	PACKING	NTF	1S (*1)
8	ガスケット	GASKET	NTF	1 (*1)
7	ステム	STEM	SUS316	1
4	シート	SEAT	*	2
3	ボール	BALL	SUS316 or SCS14A	1
2	フランジ	CAP	SCS14A	1
1	本体	BODY	SCS14A	1

NO.	PART NAME	MATERIAL	Q'TY	REMARKS
ACTION 加圧開, 加圧閉		TITLE 空気操作式ボール弁		
DOUBLE ACTING		PNEUMATIC OPERATED BALL VALVE (J10K)		
APPROVED	K. Shimura	CODE NO.	FPN1112NB- * -15/150	
CHECKED	Y. Kusumoto	DRAWING	FB2706-003A	
DRAWN	S.KITAGAWA	NO.	0	
DATE	2012.11. 8			

NDV NIPPON DAIYA VALVE CO., LTD.
TOKYO JAPAN

REV. 0
DATE 2012.11. 8
DRAWN S.KITAGAWA