

SO.No.

DN	d	L1	L2	W	JIS 10KRF							ACTUATOR CODE PMK-	B1	B2	B3	B4	H	APPROX. MASS (kg)	Q'TY
					D	C	n	h	t	g	f								
65	64	260	130	168	175	140	4	19	18	116	2	010SS	178	140	56	122	425	27.5	
80	76	280	140	194	185	150	8	19	18	126	2	010SS	178	140	56	122	435	31.5	
100												010SS	178	140	56	122	467	46.0	
100	102	340	170	233	210	175	8	19	18	151	2	030SS	197	152	63	134	502	48.5	
125												030SS	197	152	63	134	537	72.5	
125	127	370	185	281	250	210	8	23	20	182	2	060SS	272	200	73	199	659	90.0	
150												030SS	197	152	63	134	558	91.5	
150	152	430	215	321	280	240	8	23	22	212	2	060SS	272	200	73	199	680	105.0	
150												080SS	272	200	73	199	680	105.0	
200												060SS	272	200	73	199	740	170.0	
200	203	520	260	399	330	290	12	23	22	262	2	080SS	272	200	73	199	740	170.0	

流路切換状態図
Flow Diagrams
(数字はポジションを表わします。
①,②: Position No.)

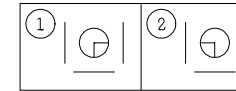

※	シート材料	SEAT MATERIAL
NTF	R.PTFE	(NEW PTFE)
NCF	R.PTFE	(カーボンファイバ入 CARBON FIBER FILLED)
NGR	R.PTFE	(ガラスファイバ入 GLASS FIBER FILLED)

NOTE
(*1) NEW PTFE

700	電動操作機	ACTUATOR		1S	
76B	六角ナット	NUT	SUS304	2	DN65~100
76A	六角ナット	NUT	SUS304	2	DN65~100
70F	長ねじボルト	STUD BOLT	SUS304	2	DN65~100
70C	六角ボルト	BOLT	SS400	4	
60	ジョイント	COUPLING	SS400	1	
55	キー	KEY	S45C	1	
45	ヨーク	YOKE	SS400	1	
19D	六角ボルト	BOLT	SUS304	4	DN125~200
19	六角ボルト	BOLT	SUS304	2	DN125~200
18A	ナット	NUT	SUS303	6~12	
18	植込みボルト	STUD BOLT	SUS304	6~12	
15C	ステム軸受	BEARING	NTF	1	(*1)
15B	パッキン押え輪	GLAND	SUS304	1	
15A	パッキン押え	GLAND FLANGE	SCS13A	1	
12B	スラスト座金	THRUST WASHER	NTF	1	(*1)
12A	軸受	BEARING	NTF	1	(*1)
12	パッキン	PACKING	NTF	1S	(*1)
8	ガスケット	GASKET	NTF	1	(*1)
7	ステム	STEM	SUS316	1	
4	シート	SEAT	*	2	
3	ボール	BALL	SCS14A	1	
2	フランジ	CAP	SCS14A	1	
1	本体	BODY	SCS14A	1	

NO.	PART NAME	MATERIAL	Q'TY	REMARKS
ACTION		TITLE		
APPROVED		ELECTRIC OPERATED		
CHECKED		3-WAY BALL VALVE (J10K)		
DRAWN		CODE NO.	EPMK4312NB-L2-*65/200	
DATE		DRAWING NO.	FB2697-006A	
		REV.	1	

NDV NIPPON DAIYA VALVE CO., LTD.
TOKYO JAPAN

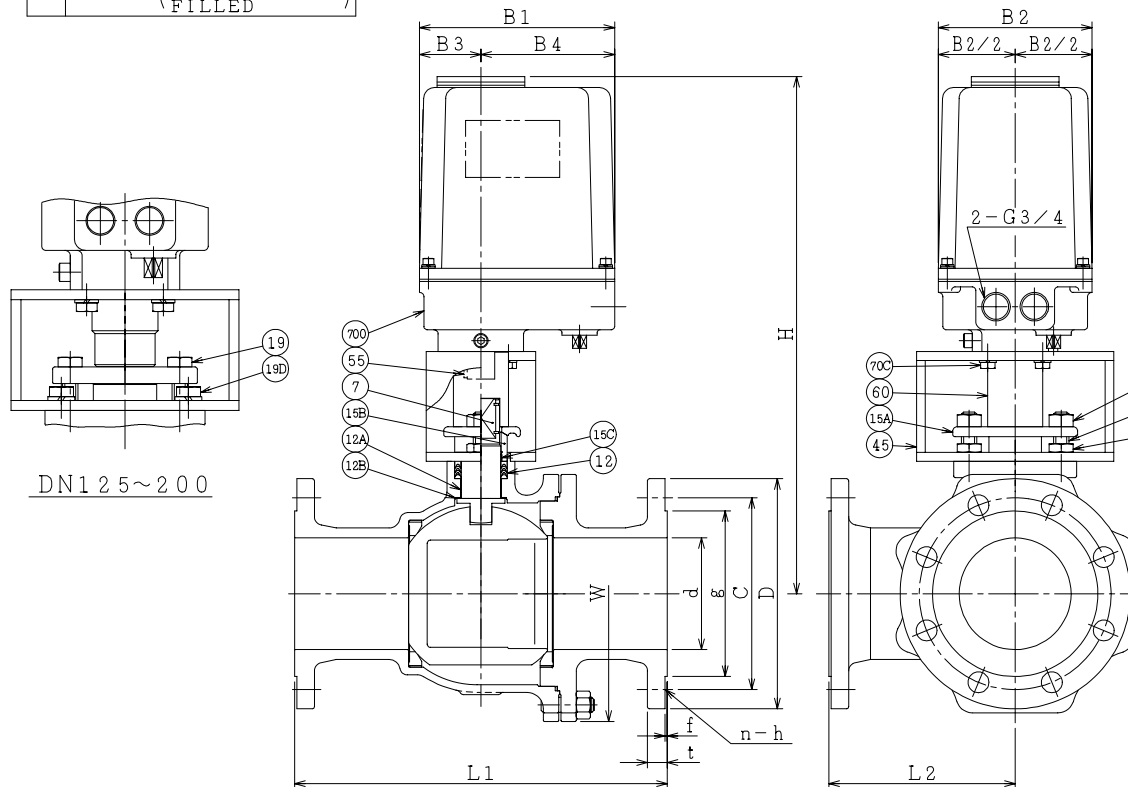

DN125~200

REV. NO. 1
DATE 13. 4. 16
REV. 0
DATE 05. 3. 4
DRAWN Y. MIZUSHIMA