

SO.No.

NPS	DN	d	L	L1	W	ASME or JPI CLASS 150RF						ACTUATOR CODE FPMK-	B1	B2	B3	B4	H	APPROX. MASS (kg)	Q'TY	
						D	C	n	h	t	g									f
2-1/2	65	64	190	87	168	178	139.7	4	19	18.0	104.6	1.6	010SS	178	140	56	122	425	22.0	
3	80	76	203	97	194	190	152.4	4	19	19.5	127.0	1.6	010SS	178	140	56	122	435	25.0	
4	100												010SS	178	140	56	122	467	37.0	
4	100	102	229	116	233	229	190.5	8	19	24.0	157.2	1.6	030SS	197	152	63	134	502	39.5	
5	125												030SS	197	152	63	134	537	58.5	
5	125	127	356	148	281	254	215.9	8	22	24.0	185.6	1.6	060SS	272	200	73	199	659	76.0	
6	150												060SS	272	200	73	199	680	87.0	
6	150	152	394	173	321	279	241.3	8	22	25.5	215.9	1.6	080SS	272	200	73	199	680	87.0	
8	200												060SS	272	200	73	199	740	128.0	
8	200	203	457	207	399	343	298.4	8	22	28.5	269.7	1.6	080SS	272	200	73	199	740	128.0	

NOTE

配管接続部のRF面は平滑加工になります。

The finishes of contact faces of end flanges:Smooth

※	シート材料	SEAT MATERIAL
NTF	R.PTFE	(NEW PTFE)
NCF	R.PTFE	(カーボンファイバ入り CARBON FIBER FILLED)
NGR	R.PTFE	(ガラスファイバ入り GLASS FIBER FILLED)

NOTE

(*1) ASTM A351

(*2) NEW PTFE

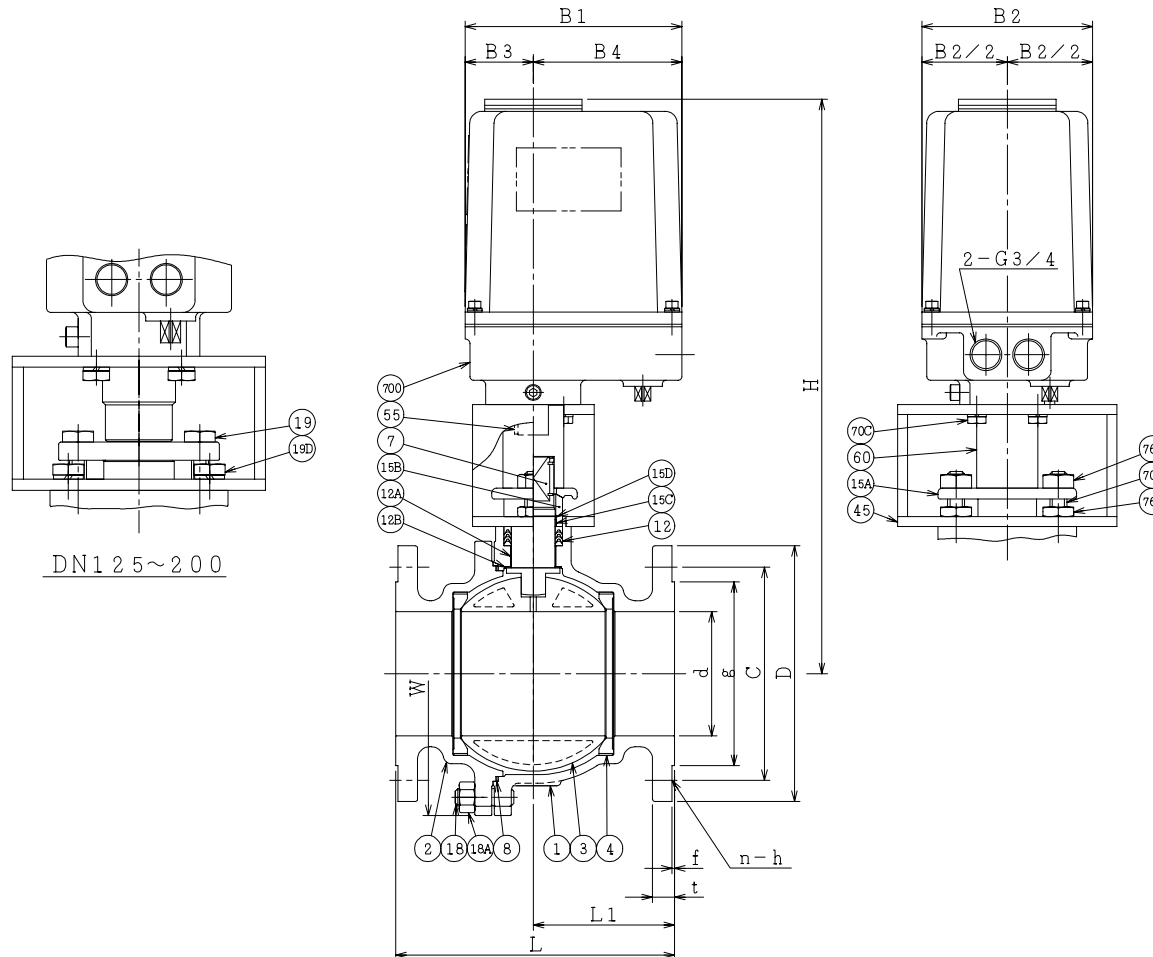

700	電動操作機	ACTUATOR		1S	
76B	六角ナット	NUT	SUS304	2	DN65~100
76A	六角ナット	NUT	SUS304	2	DN65~100
70F	長ねじボルト	STUD BOLT	SUS304	2	DN65~100
70C	六角ボルト	BOLT	SS400	4	
60	ジョイント	COUPLING	SS400	1	
55	キー	KEY	S45C	1	
45	ヨーク	YOKE	SS400	1	
19D	六角ボルト	BOLT	SUS304	4	DN125~200
19	六角ボルト	BOLT	SUS304	2	DN125~200
18A	ナット	NUT	SUS303	6~12	
18	植込みボルト	STUD BOLT	SUS304	6~12	
15D	ワイヤースプリング	WIRE SPRING	SUS304	1	
15C	ステム軸受	BEARING	NTF	1	(*2)
15B	パッキン押え輪	GLAND	SUS304	1	
15A	パッキン押え	GLAND FLANGE	SCS13A	1	
12B	スラスト座金	THRUST WASHER	NTF	1	(*2)
12A	軸受	BEARING	NTF	1	(*2)
12	パッキン	PACKING	NTF	1S	(*2)
8	ガスケット	GASKET	NTF	1	(*2)
7	ステム	STEM	SUS316L	1	
4	シート	SEAT	*	2	
3	ボール	BALL	SUS316L or SCS16A	1	
2	フランジ	CAP	CF3M	1	(*1)
1	本体	BODY	CF3M	1	(*1)

NO.	PART NAME	MATERIAL	Q'TY	REMARKS
ACTION		TITLE 電動操作式ボール弁 ELECTRIC OPERATED BALL VALVE (CL150)		
APPROVED	K. Shimura	CODE NO.	FPMK4113NB-※-65/200	
CHECKED	Y. Kusumoto	DRAWING NO.	FB2682-065A	
DRAWN	S.KITAGAWA	REV.	0	
DATE	2013. 4.25			

REMARK: 部番3はDN125~200が破線の形状になります。
The shape of DN125~200 ball is as shown by imaginary line.

NDV NIPPON DAIYA VALVE CO., LTD.
TOKYO JAPAN

REV. 0
DATE 2013. 4.25
DRAWN S.KITAGAWA

REV. NO.
DATE