

SO.No.

NPS	DN	d	L	L1	W	ASME or JPI CLASS 150RF										ACTUATOR CODE SRH-	A	B	C	D	H	APPROX. MASS (kg)	Q'TY
						D	C	n	h	t	g	f											
1/2	15	13	108	45	72	89	60.5	4	16	11.5	35.1	1.6	007	100	108	75	60	213	7.3				
3/4	20	19	117	50	78	99	69.8	4	16	11.5	42.9	1.6	007	100	108	75	60	217	8.5				
1	25	25	127	51	96	108	79.2	4	16	11.5	50.8	1.6	007	100	108	75	60	233	9.7				
1-1/4	32	38	165	70.5	124	117	88.9	4	16	13.0	63.5	1.6	007	100	108	75	60	251	12.4				
1-1/2	40	38	165	70.5	124	127	98.6	4	16	14.5	73.2	1.6	007	100	108	75	60	251	12.9				
2	50	51	178	80.5	146	152	120.6	4	19	16.0	91.9	1.6	007	100	108	75	60	259	16.6				
2	50	51	178	80.5	146	152	120.6	4	19	16.0	91.9	1.6	020	121	135	90	63	279	19.1				
2-1/2	65	64	190	87	168	178	139.7	4	19	18.0	104.6	1.6	007	100	108	75	60	287	22.5				
2-1/2	65	64	190	87	168	178	139.7	4	19	18.0	104.6	1.6	020	121	135	90	63	307	26.5				
3	80	76	203	97	194	190	152.4	4	19	19.5	127.0	1.6	020	121	135	90	63	317	30.0				
3	80	76	203	97	194	190	152.4	4	19	19.5	127.0	1.6	060	158	164	133	85	340	35.0				
4	100	102	229	116	233	229	190.5	8	19	24.0	157.2	1.6	020	121	135	90	63	351	42.0				
4	100	102	229	116	233	229	190.5	8	19	24.0	157.2	1.6	060	158	164	133	85	375	47.0				
5	125	127	356	148	281	254	215.9	8	22	24.0	185.6	1.6	060	158	164	133	85	413	68.0				
6	150	152	394	173	321	279	241.3	8	22	25.5	215.9	1.6	060	158	164	133	85	433	85.0				

NOTE

DN50以下のボルト穴(h)は鑄放しとなります。
 配管接続部のRF面は平滑加工になります。
 The finishing for bolt holes (h) of DN50 or smaller is steel casting unmachined.
 The finishes of contact faces of end flanges: Smooth

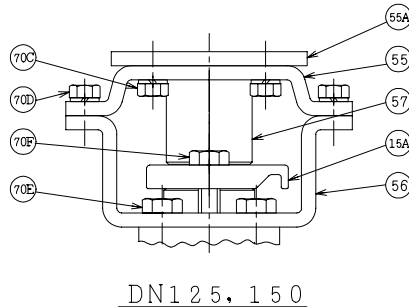
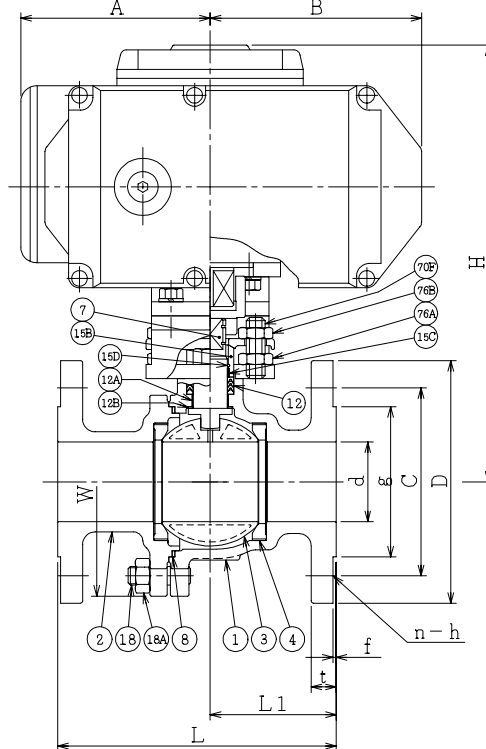
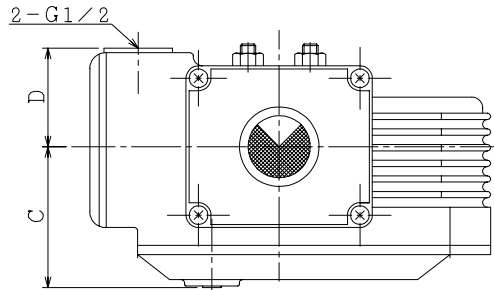

DN125, 150

REMARK:

部番3は、DN125, 150のみ、破線の形状となります。
 The shape of DN125, 150 ball is as shown by imaginary line.

*	シート材料	SEAT MATERIAL
NTF	R.PTFE	(NEW PTFE)
NCF	R.PTFE	(カーボンファイバ入 CARBON FIBER FILLED)
NGR	R.PTFE	(ガラスファイバ入 GLASS FIBER FILLED)

NOTE

- (*1) ASTM A351
- (*2) NEW PTFE

700	電動操作機	ACTUATOR		1S	
76B	六角ナット	NUT	SUS304	2	DN15~100
76A	六角ナット	NUT	SUS304	2	DN15~100
70F	六角ボルト	BOLT	SUS304	2	DN125, 150
	長ねじボルト	STUD BOLT	SUS304	2	DN15~100
70E	六角ボルト	BOLT	SUS304	2	DN125, 150:4
70D	六角ボルト	BOLT	SUS304	4	
70C	六角ボルト	BOLT	SUS304	4	
57	カップリング	COUPLING	SUS	1	
56	ヨーク B	YOKE B	SS400	1	
55A	ヨークデイスタンス	DISTANCE	SS400	1	SRH020, 060
55	ヨーク A	YOKE A	SS400	1	
18A	ナット	NUT	SUS303	4~8	
18	植込みボルト	STUD BOLT	SUS304	4~8	
15D	ワイヤースプリング	WIRE SPRING	SUS304	1	
15C	ステム軸受	BEARING	NTF	1	(*2)
15B	パッキン押え輪	GLAND	SUS304	1	
15A	パッキン押え	GLAND FLANGE	SCS13A	1	
12B	スラスト座金	THRUST WASHER	NTF	1	(*2)
12A	軸受	BEARING	NTF	1	(*2)
12	パッキン	PACKING	NTF	1S	(*2)
8	ガスケット	GASKET	NTF	1	(*2)
7	ステム	STEM	SUS304	1	
4	シート	SEAT	*	2	
3	ボール	BALL	SUS304 or SCS13A	1	
2	フランジ	CAP	CF8	1	(*1)
1	本体	BODY	CF8	1	(*1)

NO.	PART NAME	MATERIAL	Q'TY	REMARKS
ACTION		TITLE		
		電動操作式ボール弁 MOTOR OPERATED BALL VALVE (CL150)		
APPROVED	K. Shimura	CODE NO.	FSR4107NB-* -15/150	
CHECKED	Y. Kusumoto	DRAWING NO.	FB2680-034A	
DRAWN	S.KITAGAWA	DATE	2013. 4.25	REV. 0

REV. NO. DATE
 REV. 0 DATE 2013. 4.25 DRAWN S.KITAGAWA