

SO.No.

JIS 20KRF							
DN	D	C	n	h	t	g	f
125	270	225	8	25	26	195	2
150	305	260	12	25	28	230	2
200	350	305	12	25	30	275	2

DN	d	L	L1	W	H	E	APPROX. MASS (Kg)	Q' TY
125	127	381	158	296	260	1000	59.0	
150	152	403	178	321	280	1000	75.0	
200	203	502	235	414	350	1600	123.0	

ANSI or JPI CLASS 300RF							
DN	D	C	n	h	t	g	f
125	279	235.0	8	22	35.5	185.6	1.6
150	318	269.7	12	22	37.0	215.9	1.6
200	381	330.2	12	26	41.5	269.7	1.6

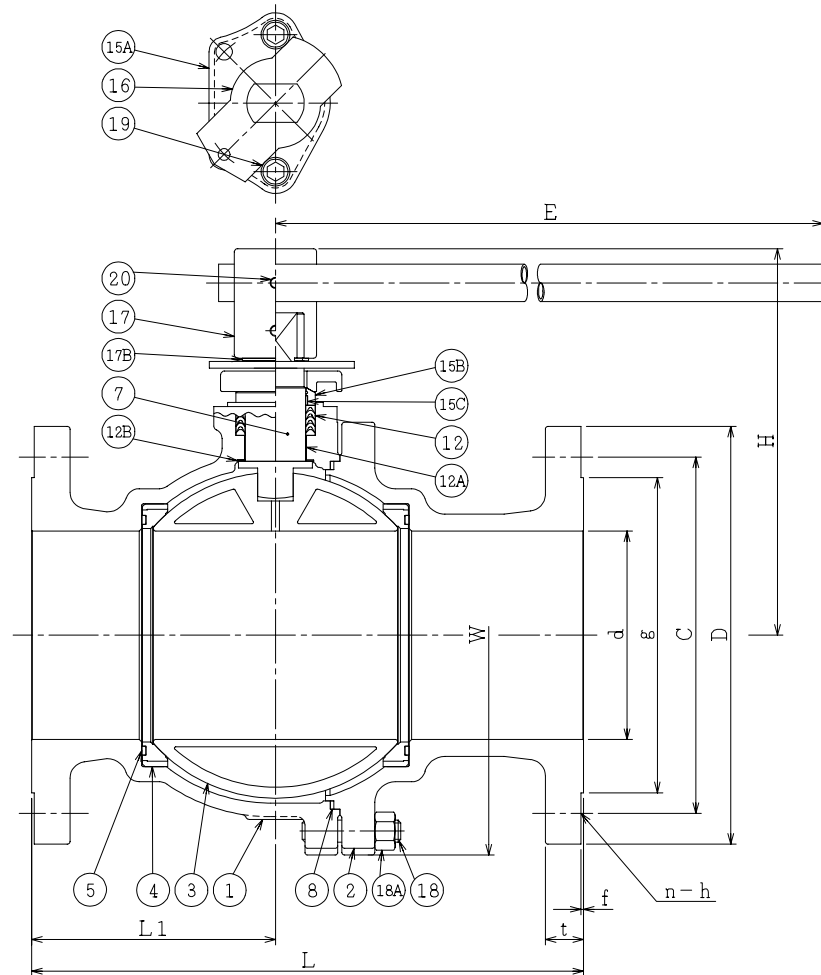

NOTE

- (*1) ASTM A351
- (*2) FIBER REINFORCED GRAPHITE
- (*3) NEW PTFE

20	六角穴付き止ねじ	SET SCREW	SUS304	2	
19	六角穴付きボルト	CAP SCREW	SUS304	2	
18A	ナット	NUT	SUS303	8~12	
18	植込みボルト	STUD BOLT	SUS304	8~12	
17B	止め輪	RETAINING RING	SUS304	1	
17	ハンドル	HANDLE	SCPH ² +STK490	1S	
16	ストッパ	TRAVEL STOP	SUS304	1	
15C	ステム軸受	BEARING	NTF	1	(*3)
15B	パッキン押え輪	GLAND	SUS304	1	
15A	パッキン押え	GLAND FLANGE	SCS13A	1	
12B	スラスト座金	THRUST WASHER	NTF	1	(*3)
12A	軸受	BEARING	NTF	1	(*3)
12	パッキン	PACKING	NTF	1S	(*3)
8	ガスケット	GASKET	GRAPHITE	1	(*2)
7	ステム	STEM	SUS304	1	
5	シートガスケット	GASKET	GRAPHITE	1	(*2)
4	シート	SEAT	CARBON +SUS316	2	
3	ボール	BALL	SUS304	1	
2	フランジ	CAP	CF8(*1) SCS13A	1	CL300 J20K
1	本体	BODY	CF8(*1) SCS13A	1	CL300 J20K

NO.	PART NAME	MATERIAL	Q'TY	REMARKS
ACTION		TITLE 手動操作式ボール弁 MANUAL OPERATED BALL VALVE (J20K, CL300)		
APPROVED	<i>K. Shimura</i>	CODE NO.	F107NB-CB-125/200	
CHECKED	<i>M. Suda</i>	DRAWN	R. KATO	DRAWING NO.
DATE	* 05.10.5	NO.	FB0594-015A	REV. 1

NDV NIPPON DAIYA VALVE CO., LTD.
TOKYO JAPAN

REV NO. 1
DATE * 05.10.5

R. KATO

REV 0
DRAWN

DATE * 05.7.27