

SO.No.

JIS 10KRF							
DN	D	C	n	h	t	g	f
15	95	70	4	15	12	51	1
20	100	75	4	15	14	56	1
25	125	90	4	19	14	67	1
32	135	100	4	19	16	76	2
40	140	105	4	19	16	81	2
50	155	120	4	19	16	96	2
65	175	140	4	19	18	116	2
80	185	150	8	19	18	126	2
100	210	175	8	19	18	151	2

DN	d	L	L1	W	H1	H2	E	APPROX. MASS (kg)	Q' TY
15	13	108	45	72	95	-	200	2.1	
20	19	117	50	78	100	-	200	2.7	
25	25	127	51	96	115	-	230	4.5	
32	38	165	70.5	124	130	-	400	7.0	
40	38	165	70.5	124	130	-	400	7.0	
50	51	178	80.5	146	135	-	400	9.1	
65	64	190	87	168	-	155	600	14.0	
80	76	203	97	194	-	165	600	17.5	
100	102	229	116	233	-	205	800	28.5	

ASME or JPI CLASS 150RF									
NPS	DN	D	C	n	h	t	g	f	
1/2	15	89	60.5	4	16	11.5	35.1	1.6	
3/4	20	99	69.8	4	16	11.5	42.9	1.6	
1	25	108	79.2	4	16	11.5	50.8	1.6	
1-1/4	32	117	88.9	4	16	13.0	63.5	1.6	
1-1/2	40	127	98.6	4	16	14.5	73.2	1.6	
2	50	152	120.6	4	19	16.0	91.9	1.6	
2-1/2	65	178	139.7	4	19	18.0	104.6	1.6	
3	80	190	152.4	4	19	19.5	127.0	1.6	
4	100	229	190.5	8	19	24.0	157.2	1.6	

NOTE
 DN50以下のボルト穴(h)は鑄放しとなります。
 配管接続部のRF面は平滑加工になります。
 The finishing for bolt holes (h) of DN50 or smaller is steel casting unmachined.
 The finishes of contact faces of end flanges:Smooth

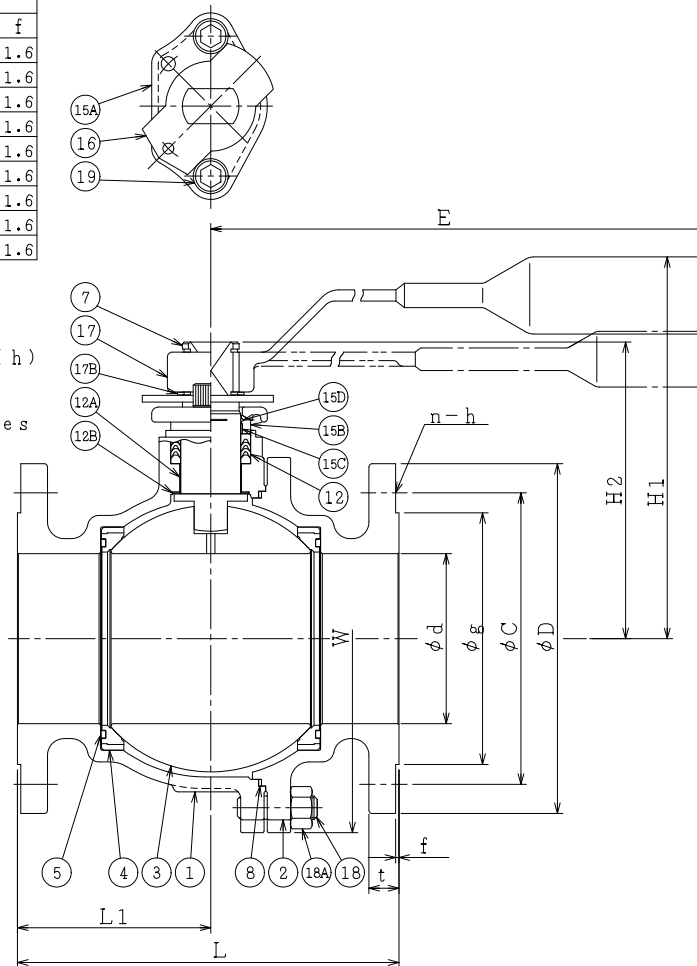

NOTE

(*1) ASTM A351

(*2) FIBER REINFORCED GRAPHITE

(*3) NEW PTFE

19	六角穴付きボルト	CAP SCREW	SUS304	2	
18A	ナット	NUT	SUS303	4~8	
18	植込みボルト	STUD BOLT	SUS304	4~8	
17B	止め輪	RETAINING RING	SUS304	1	
17	ハンドル	HANDLE	SCPH2 +STK500	1	
16	ストッパ	TRAVEL STOP	SUS304	1	
15D	ワイヤースプリング	WIRE SPRING	SUS304	1	
15C	ステム軸受	BEARING	NTF	1	(*3)
15B	パッキン押え輪	GLAND	SUS304	1	
15A	パッキン押え	GLAND FLANGE	SCS13A	1	
12B	スラスト座金	THRUST WASHER	NTF	1	(*3)
12A	軸受	BEARING	NTF	1	(*3)
12	パッキン	PACKING	NTF	1S	(*3)
8	ガスケット	GASKET	GRAPHITE	1S	(*2)
7	ステム	STEM	SUS316L	1	DN15,20:SUS329J1
5	シートガスケット	GASKET	GRAPHITE	2	(DN32~100:*2)
4	シート	SEAT	CARBON +SUS316	2	
3	ボール	BALL	SUS316L or SCS16A	1	
2	フランジ	CAP	CF3M(*1) SCS16A	1	CL150 J10K
1	本体	BODY	CF3M(*1) SCS16A	1	CL150 J10K

NO.	PART NAME	MATERIAL	Q'TY	REMARKS
ACTION		TITLE 手動操作式ボール弁 MANUAL OPERATED BALL VALVE (J10K, CL150)		
APPROVED	<i>Y. Kusunoki</i>	CODE NO.	F113NB-CB-15/100	
CHECKED	<i>Y. Mitsuhashi</i>	DRAWING NO.	FB0594-006A	
DRAWN	Y. KUSUNOKI	REV.	2	
DATE	2015. 4. 1			

NDV NIPPON DAIYA VALVE CO., LTD.
 TOKYO JAPAN

REV NO. 2
 DATE 15. 4. 1
 REV 0
 DATE 04.12.24
 DRAWN M.SUZUKI