

SO.No.

| JIS 10KRF | | | | | | | |
|-----------|-----|-----|---|----|----|-----|---|
| DN | D | C | n | h | t | g | f |
| 15 | 95 | 70 | 4 | 15 | 12 | 51 | 1 |
| 20 | 100 | 75 | 4 | 15 | 14 | 56 | 1 |
| 25 | 125 | 90 | 4 | 19 | 14 | 67 | 1 |
| 32 | 135 | 100 | 4 | 19 | 16 | 76 | 2 |
| 40 | 140 | 105 | 4 | 19 | 16 | 81 | 2 |
| 50 | 155 | 120 | 4 | 19 | 16 | 96 | 2 |
| 65 | 175 | 140 | 4 | 19 | 18 | 116 | 2 |
| 80 | 185 | 150 | 8 | 19 | 18 | 126 | 2 |
| 100 | 210 | 175 | 8 | 19 | 18 | 151 | 2 |

| DN | d | L | L1 | W | H1 | H2 | E | APPROX. MASS (kg) | Q'TY |
|-----|-----|-----|------|-----|-----|-----|-----|-------------------|------|
| 15 | 13 | 108 | 45 | 72 | 95 | - | 200 | 2.1 | |
| 20 | 19 | 117 | 50 | 78 | 100 | - | 200 | 2.7 | |
| 25 | 25 | 127 | 51 | 96 | 115 | - | 230 | 4.5 | |
| 32 | 38 | 165 | 70.5 | 124 | 130 | - | 400 | 7.0 | |
| 40 | 38 | 165 | 70.5 | 124 | 130 | - | 400 | 7.0 | |
| 50 | 51 | 178 | 80.5 | 146 | 135 | - | 400 | 9.1 | |
| 65 | 64 | 190 | 87 | 168 | - | 155 | 600 | 14.0 | |
| 80 | 76 | 203 | 97 | 194 | - | 165 | 600 | 17.5 | |
| 100 | 102 | 229 | 116 | 233 | - | 205 | 800 | 28.5 | |

NOTE

DN50以下のボルト穴(h)は鑄放しとなります。
The finishing for bolt holes (h) of DN50 or smaller is steel casting unmachined.

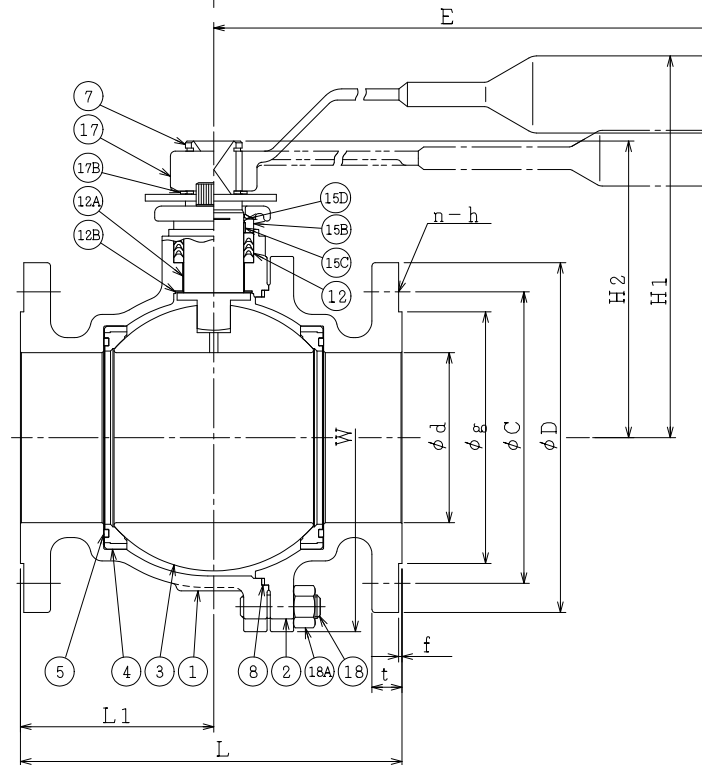
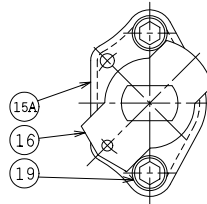

NOTE

(*1) FIBER REINFORCED GRAPHITE
(*2) NEW PTFE

| | | | | | |
|-----|-----------|----------------|-------------------|-----|-------------------|
| 19 | 六角穴付きボルト | CAP SCREW | SUS304 | 2 | |
| 18A | ナット | NUT | SUS303 | 4~8 | |
| 18 | 植込みボルト | STUD BOLT | SUS304 | 4~8 | |
| 17B | 止め輪 | RETAINING RING | SUS304 | 1 | |
| 17 | ハンドル | HANDLE | SCPH2 +STK500 | 1 | |
| 16 | ストッパ | TRAVEL STOP | SUS304 | 1 | |
| 15D | ワイヤースプリング | WIRE SPRING | SUS304 | 1 | |
| 15C | ステム軸受 | BEARING | NTF | 1 | (*2) |
| 15B | パッキン押え輪 | GLAND | SUS304 | 1 | |
| 15A | パッキン押え | GLAND FLANGE | SCS13A | 1 | |
| 12B | スラスト座金 | THRUST WASHER | NTF | 1 | (*2) |
| 12A | 軸受 | BEARING | NTF | 1 | (*2) |
| 12 | パッキン | PACKING | NTF | 1S | (*2) |
| 8 | ガスケット | GASKET | GRAPHITE | 1S | (*1) |
| 7 | ステム | STEM | SUS316 | 1 | DN15, 20:SUS329J1 |
| 5 | シートガスケット | GASKET | GRAPHITE | 2 | (DN32~100:*1) |
| 4 | シート | SEAT | CARBON +SUS316 | 2 | |
| 3 | ボール | BALL | SUS316 SCS14A | 1 | |
| 2 | フランジ | CAP | SCS14A | 1 | |
| 1 | 本体 | BODY | SCS14A | 1 | |

| NO. | PART NAME | MATERIAL | Q'TY | REMARKS |
|----------|----------------------|---|------------------|---------|
| ACTION | | TITLE | | |
| | | 手動操作式ボール弁 MANUAL OPERATED BALL VALVE (J10K) | | |
| APPROVED | <i>Y. Kusunoki</i> | CODE NO. | F112NB-CB-15/100 | |
| CHECKED | <i>Y. Mitsuhashi</i> | DRAWING NO. | FB0594-005A | |
| DRAWN | Y. KUSUNOKI | REV. | 2 | |
| DATE | 2015. 4. 1 | | | |

NDV NIPPON DAIYA VALVE CO., LTD.
TOKYO JAPAN

REV. NO. 2
DATE 15. 4. 1
DRAWN M. SUZUKI
DATE 04. 12. 24