

SO.No.

NPS	DN	d	L	L1	k	J	ASME or JPI CLASS 300RF						H1	H2	E	FLANGE DN	APPROX MASS (kg)	Q'TY
							D	C	n	h	t	g						
3/4	20	19	117	58.5	(*3)	78	155	114.3	4	22	21.0	73.2	1.6	134	-	130	40	6.0
1	25	25	127	63.5	(*3)	86	165	127.0	8	19	22.5	91.9	1.6	142	-	160	50	7.4
1-1/2	40	38	165	82.5	60	99	190	149.4	8	22	25.5	104.6	1.6	160	-	230	65	12.1
2	50	51	178	93	65	105	210	168.1	8	22	28.5	127.0	1.6	169	-	230	80	16.6
2-1/2	65	64	190	100	65	118	254	200.2	8	22	32.0	157.2	1.6	-	188	350	100	25.0
3	80	76	203	108	70	131	279	235.0	8	22	35.5	185.6	1.6	-	199	350	125	35.4
4	100	102	229	119	75	148	318	269.7	12	22	37.0	215.9	1.6	-	210	450	150	53.1

NOTE

DN50以下のボルト穴(h)は鑄放しとなります。  
 配管接続部のR.F面は平滑加工になります。  
 The finishing for bolt holes (h) of DN50 or smaller is steel casting unmachined.  
 The finishes of contact faces of end flanges:Smooth

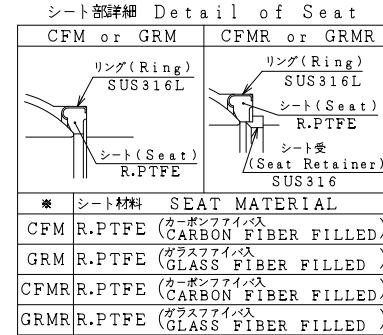

NOTE

- (\*1) 強化PTFE(Reinforced PTFE)
- (\*2) NEW PTFE
- (\*3) DN25以下のソケットはバルブ中心に取付けます。  
 For DN25 and smaller, sockets are placed with welding on the plan X-X'.

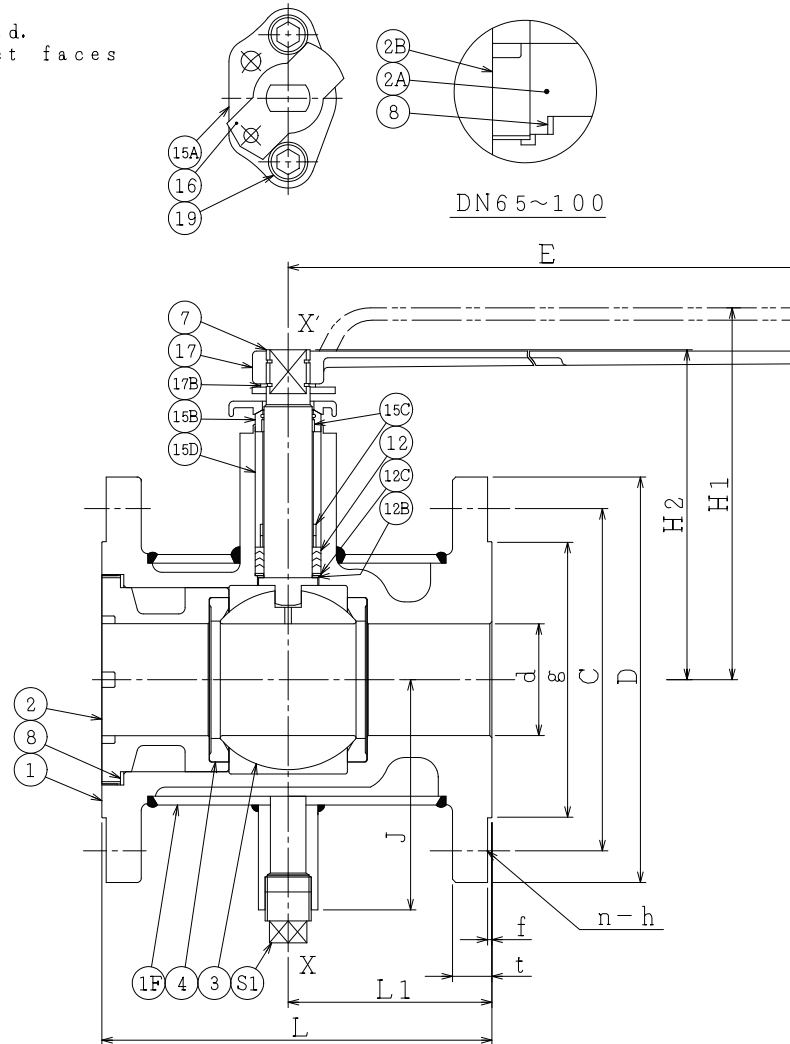
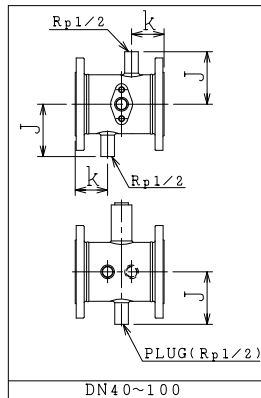
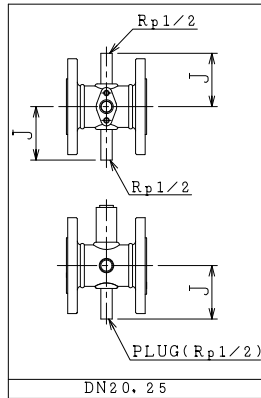

S1	プラグ	PLUG	SUS304	1	
19	六角穴付きボルト	CAP SCREW	SUS304	2	
17B	止め輪	RETAINING RING	SUS304	1	
17	ハンドル	HANDLE	SCPH2	1	
16	ストッパ	TRAVEL STOP	SUS304	1	
15D	スペーサ	SPACER	SUS304	1	
15C	ステム軸受	BEARING	R.PTFE(*1)	3	FL3000
15B	パッキン押え輪	GLAND	SUS304	1	
15A	パッキン押え	GLAND FLANGE	SCS13A	1	
12C	座金	WASHER	SUS316	1	
12B	スラスト座金	THRUST WASHER	NTF(*2)	1	
12	パッキン	PACKING	R.PTFE(*1)	1S	
8	ガスケット	GASKET	PTFE	1	
7	ステム	STEM	SUS316	1	
4	シート	SEAT	*	2	
3	ボール	BALL	SUS316 or SCS14A	1	
2B	インサート押え	INSERT RING	SCS14A	1	DN65~100
2A	インサート	INSERT	SCS14A	1	DN65~100
2	インサート	INSERT	SCS14A	1	DN20~50
1F	ジャケットカバー	JACKET	SUS304 or SUS304TP	1	
1	本体	BODY	SCS14A	1	
NO.	PART NAME		MATERIAL	Q'TY	REMARKS
ACTION		TITLE 手動操作式ボール弁 MANUAL OPERATED BALL VALVE (CL300)			
APPROVED	Y. Kusunoki		CODE NO.	E112JNC-* - 20/100	
CHECKED	Y. Ishibashi		DRAWING NO.	FB0556-012A	
DRAWN	Y. KUSUNOKI		REVISION	2	
DATE	2018.12.14				

REV. NO. 1 2  
 DATE 2018.12.14 2018.12.14  
 DRAWN K. UCHIDA  
 DATE 2005. 6.14